

REV	ECN	DESCRIPTION	BY/DATE	CHK	APPR
C	7708	ADDED VIEW ABOVE MTG SURFACE	JS 08/31/11	JV	ANS

PINOUT:
 PIN A-CASE GROUND
 PIN B-SIG/PWR GND RET
 PIN C-SIG/PWR

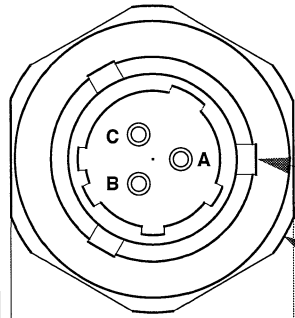

3-PIN BAYONET STYLE
 MS3443H898PN CONNECTOR,
 HERMETIC. SEE NOTE 6 FOR MATING
 CONNECTOR SUGGESTIONS.

Ø .811, HEX CORNERS

MODEL NO.	SENSITIVITY
3062A	10 mV/G
3062A1	25 mV/G

ARROW INDICATES
 DIRECTION OF
 ACCELERATION FOR
 POSITIVE OUTPUT

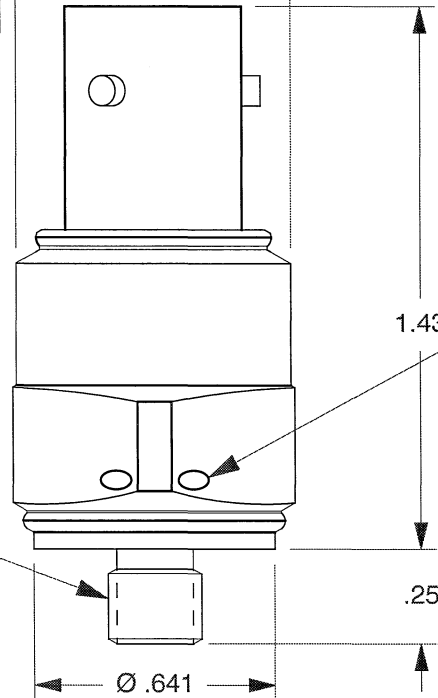

Ø.047 LOCKWIRE HOLES,
 TYP 2 HOLES

MOUNTING RECOMENDATION:
 PREPARE FLAT CIRCULAR AREA
 APPROX. Ø.750, FLAT TO WITHIN
 .001 AT CENTER, DRILL Ø.213 X
 .320 DEEP MIN
 BOTTOM TAP 1/4-28 UNF-2B X
 .270 DEEP MIN

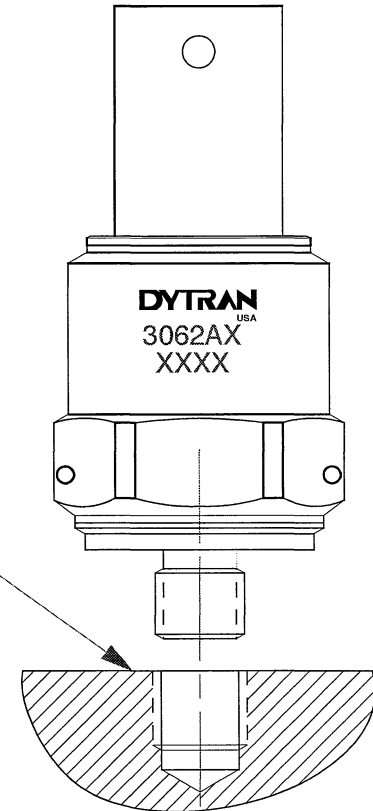

6. TYPICAL MATING CONNECTORS ARE: MS3476W898SN (STANDARD PLUG, CADMIUM FINISH). FOR PLUG W/RFI FINGERS: MS3475 W898SN. OTHER VARIATIONS ARE AVAILABLE.

- MATERIAL, BODY & CONNECTOR: 300 SERIES STAINLESS STEEL.
- SENSING ELEMENT: QUARTZ SHEAR.
- POWER/SIGNAL GROUND INSULATED FROM OUTER CASE. INSUL. RES: > 10 MEGOHMS.
- SEALING: HERMETIC.
- WEIGHT: MODEL 3062A: 37 GRAMS.
 MODEL 3062A1: 40 GRAMS.

		MASTER		CHATSORTH, CA.	
ONLY IF IN RED					
SCALE 2X	REV C	DATE -	ECN	SEE REV BLK	
DATE 9/3/96	PART NO. MODELS 3062A & 3062A1				
DRAWN N.C.	CHECKED D.Z.	MATL			
APPROVED	NEXT ASSEMBLY		USED ON		
TITLE				DWG NO.	
OUTLINE/INSTALLATION DRAWING, MODELS 3062A & 3062A1				127-3062A	
				SHEET 1 OF 1	

SPECIFICATIONS
MODEL 3062A LIVM ACCELEROMETER

SPECIFICATION	VALUE	UNITS
PHYSICAL		
WEIGHT	37	Grams
SIZE, HEX x HEIGHT	.750 x 1.4	Inches
MOUNTING PROVISION	1/4-28 x .250 long integral stud	
CONNECTOR, AXIALLY MOUNTED, HERMETIC (Pin A-case ground, Pin B-sig/pwr return, Pin C-signal/power)	MS3443-H-8-98PN	3-Pin
MATERIAL: HOUSING, BASE, CONNECTOR	300 Series	
Stainless Steel		
ELEMENT STYLE	Quartz shear	
PERFORMANCE		
SENSITIVITY, $\pm 5\%$ [1]	10	mV/G
RANGE F.S. FOR ± 5 VOLTS OUT	± 500	G's
FREQUENCY RANGE, $\pm 5\%$	0.48 to 10k	Hz
$\pm 15\%$	0.32 to 20k	Hz
RESONANT FREQUENCY, NOM.	45	kHz
EQUIVALENT ELECTRICAL NOISE FLOOR RMS	.005	G's
LINEARITY [2]	$\pm 1\%$	% F.S.
TRANSVERSE SENSITIVITY, MAX.	5	%
STRAIN SENSITIVITY	.003	G's/ $\mu\sigma$
ENVIRONMENTAL		
MAXIMUM VIBRATION/SHOCK PEAK	1000/5000	\pm G's/G's
TEMPERATURE RANGE	-60 to +305	$^{\circ}$ F
SEAL, HERMETIC	Glass-to-metal and TIG welded	
COEFFICIENT OF THERMAL SENSITIVITY	.03	%/ $^{\circ}$ F
ELECTRICAL		
SUPPLY CURRENT/COMPLIANCE VOLTAGE RANGE [3] mA/Volts	2 to 20/+18 to +30	
OUTPUT IMPEDANCE, TYP.	100	Ohms
BIAS VOLTAGE, +8 VOLTS NOM.	+7.5 to +9.5	VDC
DISCHARGE TIME CONSTANT, NOM.	1.0 to 2.0	SEC
OUTPUT SIGNAL POLARITY FOR ACCELERATION TOWARD TOP POSITIVE		
ELECTRICAL ISOLATION, Ground (Pin B) to Case	10	Megohms, min.

[1] Measured at 100 Hz, 1 G RMS per ISA RP 37.2.

[2] Measured using zero-based best straight line method, % of F.S. or any lesser range.

[3] Do not apply power to this device without current limiting, 20 mA MAX. To do so will destroy the Integral IC amplifier.