



# More Precision

Efficient LED testing

Color | Intensity | Function | Light spectrum  
LEDs and Illumination



## LED tests of function, color and intensity

Traditional displays such as bulbs, monitors and display elements with filaments are being increasingly replaced by LEDs (light-emitting diodes). The high luminous efficiency, large color spectrum and different illuminants such as visible light, infrared and ultraviolet, enable a wide variety of applications. Due to this new technology, inspection systems for these self-luminous objects have become more demanding.

Micro-Epsilon Eltrotec has taken up these tasks by bringing together its vast experience in optical fibers, color sensor technology and image processing into one product family for LED testing. Depending on their equipment, these devices are suitable for inspecting the function, color and brightness (intensity), as well as providing the test results as switch signals, values or good/bad statements. Convince yourself of the powerful performance of the Micro-Epsilon Eltrotec systems and choose the appropriate system for your measurement task.

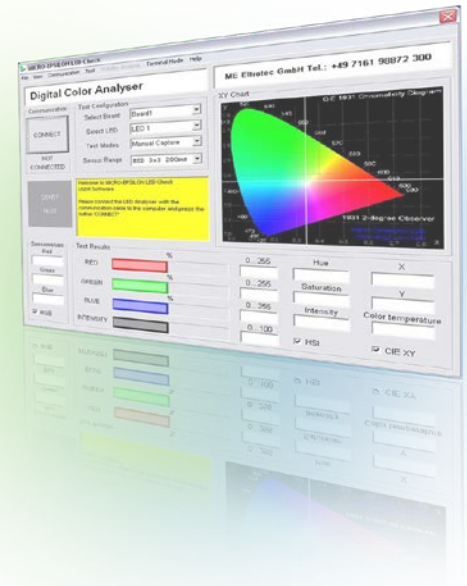

## Multiple-point color recognition

### colorCONTROL MFA-5 series

This extremely compact series enables the testing of color values, intensities and functions, up to 20 measuring points simultaneously at an excellent price/performance ratio. Optical fibers can be flexibly adapted to suit different test adapters. Due to its modular design, 5/10/15 or 20 measuring points can be requested in parallel.

- High dynamic range with intensity tests
- Modular system ready in 5 steps
- Testing of up to 20 measuring points in parallel in < 1 s
- Color inspection in the xy-, HSI- and RGB color spaces
- Color values readable via RS232 and USB interface
- Compact and easy to integrate housing
- Excellent price/performance ratio
- Free software tool



## Color sensors

### colorSENSOR CFO series

High quality testing of color values, intensities and functions of LEDs or lighting modules using True Color chip technology. These color recognition sensors determine the XYZ values of the test object and convert this to xyY and Luv.

Just like the MFA series, the CFS5-22 receiver sensor transmits the light from the light source to be measured to the colorSENSOR CFO100 controller. The great advantage of this measuring system is that up to 6 switching states (colors, intensities) can be stored in the controller and evaluated directly. In addition, the fast measurement frequency of up to 10 kHz enables the detection and evaluation of flashing frequencies of up to 2 kHz.

Up to 254 color values can be taught, stored and compared with the test object using this sensor. The RS232 or Ethernet interface enable configuration and set up of the sensors.

- Direct good/bad evaluation of the learned values in the sensor
- 254 lighting states can be taught directly via keyboard or web interface
- Precise color testing in XYZ, xyY, Lab and Luv
- Data provision via Ethernet or RS232 interface
- High color resolution with XYZ True Color sensor ( $\Delta E < 0,5$ )
- Switching frequency up to 10 kHz
- 6 color groups (4-pin binary coding)
- User-friendly web interface
- Fast mounting (DIN)



## Color measuring system

### colorCONTROL ACS7000 + ACS3-TR receiver sensor

The inline color measuring system is the most precise way of measuring color, intensity and the visible light spectrum. Visual light in the wavelength range of 390 to 780 nm is spectrally detected and evaluated in increments of 5 nm. It is possible to consider the entire light spectrum or just the desired color values. The color measurement and data transmission can also be processed in real time via the integrated RS422 and EtherCAT interfaces.

- High precision due to spectral color evaluation
- Very high measurement speeds with up to 2 kHz
- Output of visible light spectrum and wavelength
- Color measurement under standard observer 2° and 10°
- Color measurement in the XYZ,  $L^*a^*b^*$ ,  $L^*u^*v^*$  color space
- Sensor head with 5 mm and 9 mm measurement spot sizes available
- Data provision via Ethernet/EtherCAT or RS422
- Clock output for control of other sensors
- User-friendly web interface
- Fast mounting (DIN)

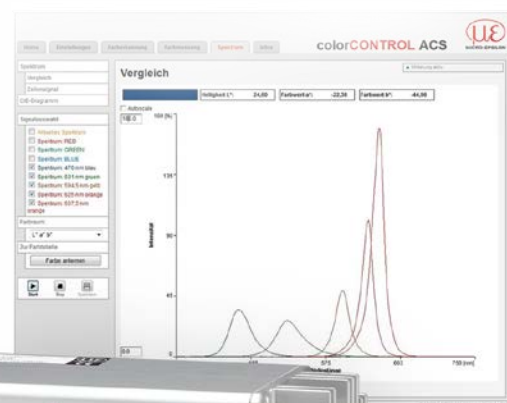



- Multipoint color recognition system
- Optionally with up to 495 channels
- Color inspection in HSI and RGB color spaces
- Color differentiation/intensity tests/function tests

#### Features:

- Versatile coupling possibilities for fiber optics
- Individual configuration of fiber optics
- Each measuring position is freely configurable in terms of color, intensity and function
- Integration into testing process
- Good/bad evaluation
- Output of HSI, RGB and xy values via RS232 or USB
- External trigger
- Exchangeable adapter for fiber optics
- Suitable for POF (2 m) and optical glass fiber optics up to 5 m
- Up to 20 testing points using different assembly kits

#### Applications:

- Testing self-luminous objects
- LED tests (binning)
- Indication tests
- Display tests
- Seven-segment display tests
- Parallel and simultaneous inspection of up to 495 channels  $\leq 1$  s
- Front panel tests
- With external illumination, multipoint color testing is possible

#### Function:

The information about color, intensity and light are directly transmitted from the measuring object to the MFA sensor via single fiber bundles and evaluated at up to 20 points at the same time.

The inspection of inaccessible specimens and/or specimens situated far apart from one another can easily be achieved using the MFA series, as optical fibers transmit the information to the evaluation unit.

Using the colorCONTROL MFA-5-M expansion module, the colorCONTROL MFA-5 can be extended by 5 testing points to 20 testing points. Additionally, one of the assembly kits is required depending on the construction depths (see accessories). For example: 20 testing points require: 1x colorCONTROL MFA-5 + 3x colorCONTROL MFA-5-M + 1x assembly kit MFA-20.

The colorCONTROL MFA-5-P board model is delivered without protection housing and can be interconnected with other MFA-5-P sensors. Here it is possible to switch up to 99 MFA-5-P sensors in series and to test 495 channels simultaneously.

Model	MFA-5	MFA-5-M <sup>1)</sup>	MFA-5-P <sup>2)</sup>
Article number	11094050	11094051	11094052
Detection points	5	extension of MFA-5 by 5 each	5
Test spectrum		450 - 650 nm	
Supply voltage	24 VDC $\pm$ 10 % residual ripple	24 VDC via MFA-5	5 VDC
Current consumption	80 mA - 320 mA	160 - 320 mA	80 mA
Interface	RS232, USB, Daisy Chain	Daisy Chain	RS232, USB, Daisy Chain
Accuracy	$\pm$ 4 nm		
Resolution	9 - 81 pixels / detection point		
Object distance	typ. 1 - 5 mm		
Optical fiber (length)	incl. POF $\varnothing$ 2,2 mm <sup>3)</sup> x 0.5 m; max. POF 2 m / glass 5 m		
Color space	HSI, RGB, xy + color temperature in K		
Dynamic range	200 lx - 4000 lx		
Testing frequency	$\leq$ 1 Hz (100 detection points $\leq$ 1 s)		
Operating temperature	0 ... +50 °C		
Humidity	20% to 80% rel. humidity (non-condensing)		
Protection class	IP50	IP50	IP0

<sup>1)</sup> Modular expansion to 10/15/20 measuring positions

<sup>2)</sup> Modular expandable to 495 channels (99 pieces in series connection)

<sup>3)</sup> Reduction to  $\varnothing$  1.0 mm is possible with reducing adapter

### Dimensions:

Dimensions in mm, not to scale

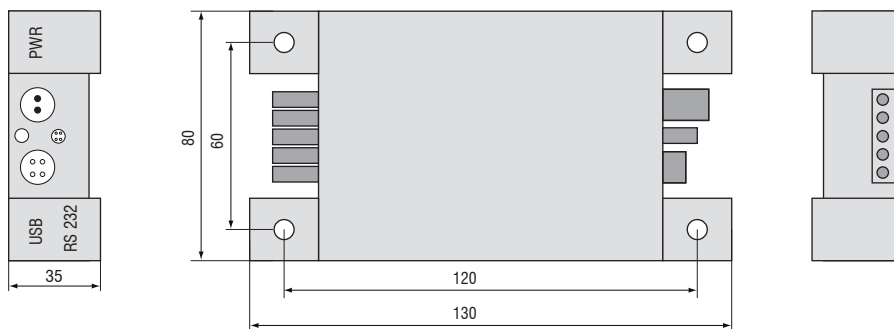



- 256 colors can be saved
- Repeatability  $\leq 0.5$
- Easy key operation
- Automatic LED control
- Fiber optics with focus lenses
- Multi-teach function

#### Features:

- Color memory: 256 colors in 6 color groups can be saved using keys
- Max. 3 color channels (6 with binary coding)
- Ethernet interface
- White light LED
- Color inspection in the  $L^*a^*b^*$  /  $L^*u^*v^*$  color space
- Different evaluation algorithms can be activated
- 6 color groups
- Adaptable fiber optics and focus lenses
- Robust aluminum housing
- Measurement frequency up to 10 kHz

#### Application examples:

- Precise color testing of self-luminous objects
- Illumination module
- Interior lighting - automobile
- Interior lighting - cockpit

The colorSENSOR CFO100 is a new sensor for precise color recognition for industrial measurement tasks. The controller is distinguished by high color accuracy, state-of-the-art interfaces and intuitive operation. Fiber optics which can be adapted for various measuring tasks, are connected to the controller.

Using a modulated high-power white light LED, a white light spot is projected via the fiber optics onto the surface to be detected. Part of the light that is back scattered from the target is directed onto a perceptive True Color detector via the same fiber optics, separated into long-, medium- and short-wave light components (X=long, Y=medium, Z=short) and transformed into  $L^*a^*b^*$  color values.

Intuitive key operation enables the user to easily teach-in up to 256 colors in 6 color groups. One function alone adapts the illumination, averaging and signal amplification to the current measurement situation. Furthermore, tolerance models and tolerance values can be adjusted individually.

If the sensor recognizes one of the taught colors, the switching state changes via three digital outputs. Binary output switching ensures reliable test performance in the face of a discontinuity while providing output of up to 6 color groups.

Equipped with optical fibers, the sensor can also be used in restricted areas as the sensor head requires a minimum of space.

Model	CFO100
Article number	10234670
Object distance	depends on the fiber optics and the ancillary lens used reflected-light optical fiber typ. 2 mm - 25 mm with lens typ. 5 mm - 100 mm <sup>2)</sup>
Light spot diameter	depending on the fiber optics used as well as front lens attachment reflected-light optical fiber typ. dia. 0.6 mm - 20 mm <sup>2)</sup>
Repeatability <sup>1)</sup>	$\Delta E \leq 0.5$
Color distance	$\Delta E \leq 1.0$
Color spaces	XYZ, xyY, L*a*b*, L*u*v*, u'vL*
Averaging	automatic adaption depending on the measurement frequency over max. 200 values
Size of color memory	max. 256 colors in non-volatile EEPROM with parameter sets
Measurement frequency	Standard 1 kHz; max. 10 kHz (number of colors being taught and the setting for the averaging depend on this)
Temperature drift X,Y	0.1 % / K
Light source	white light LED, AC mode (adjustable or OFF for self-luminous objects, software-switchable)
Type of illumination	via fiber optics
Effect from illumination	automatically adjustable
Ambient light	up to 5000 lux
Alternating light operation	AC: typ. 1 kHz; max. 10 kHz
Power supply	+18 ... 28 VDC
Power consumption	typ. 500 mA
Max. switching current	100 mA
TEACH key/inputs	5 keys and IN0 for externally teaching color reference, tolerance stage and configuring sensor
Outputs	OUT 0 - OUT 2, digital (0V/+Ub), 100 mA max. switching current
Switching state display	visualization with 13 white LEDs
Interface	Ethernet and RS232 process interface
Type of connector	to power/PLC: 8-pole flange connector (M12A) to PC: 4-pole flange socket (M12D) (Ethernet DHCP-capable)
Connection cable	to power/PLC: art. no. 11234717 / to PC: art. no. 11234735 (Ethernet)
Receiver	3-color filter detector (XYZ TRUE COLOR detector, color curve according to CIE1931)
Pulse extension	off by default, typ. 10 ms, adjustable > 30 $\mu$ s
Signal amplification	2 stages, automatic
Housing material	Aluminum, anodized black
Operating temperature	-10 ... +55 °C
Storage temperature	-10 ... +85 °C
Protection class	IP65

<sup>1)</sup> Maximum color distance  $\Delta E$  of 1000 successive measurements of the color value of a red and a dark gray reference tile (R = 5%), measured with sensor FAR-TA2.0-2.5-1200-67<sup>2)</sup> at 1000 Hz and brightness adjustment with a white standard (R=95%)

<sup>2)</sup> Model: FAR - T - A2.0 - 2.5 - 1200 - 67 Reflex

Model: FAD - T - A2.0 - 2.5 - 1200 - 67 Transmitted light

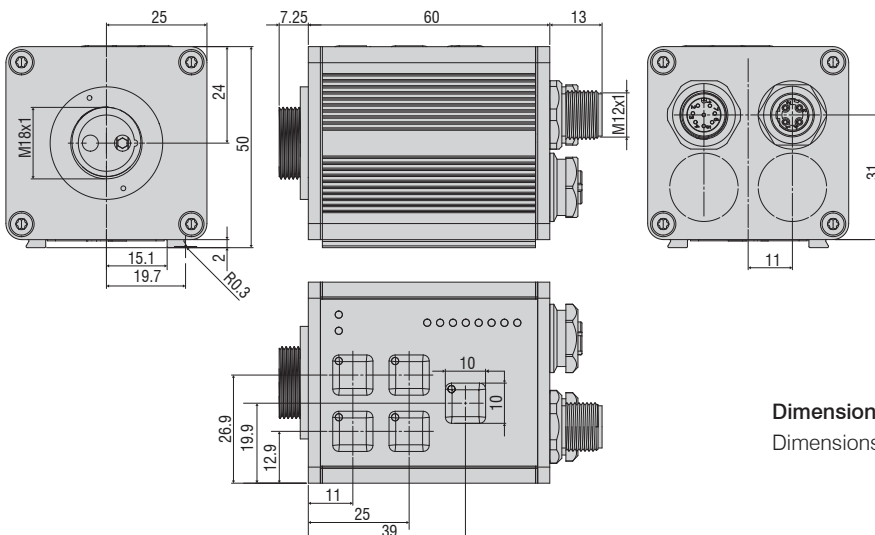

#### Dimensions:

Dimensions in mm, not to scale



- *More than 320 colors can be saved*
- *Repeatability  $\leq 0.3$*
- *Easy key operation*
- *Automatic LED control*
- *Fiber optics with focus lenses*
- *Multi-teach function*

#### Features:

- Color memory: > 320 colors in 254 color groups can be saved using keys
- Max. 8 color channels (254 with binary coding)
- Ethernet interface
- White light LED
- Color inspection in the  $L^*a^*b^*$  /  $L^*u^*v^*$  color space
- Different evaluation algorithms can be activated
- 254 color groups
- Adaptable fiber optics and focus lenses
- Robust aluminum housing
- Measurement frequency up to 20 kHz

#### Application examples:

- Very precise color testing of self-luminous objects
- Illumination module
- Interior lighting - automobile
- Interior lighting - cockpit
- Illumination of switch elements
- Color testing with background lighting
- Ambient lighting

The colorSENSOR CFO200 is a new sensor for precise color recognition in industrial measurement tasks. The controller is distinguished by high color accuracy, state-of-the-art interfaces and intuitive operation. Fiber optics which can be adapted for various measuring tasks, are connected to the controller.

Using a modulated high-power white light LED, a white light spot is projected via the fiber optics onto the surface to be detected. Part of the light that is back scattered from the target is directed onto a perceptive True Color detector via the same fiber optics, separated into long-, medium- and short-wave light components (X=long, Y=medium, Z=short) and transformed into  $L^*a^*b^*$  color values.

Intuitive key operation enables the user to easily teach-in more than 320 colors in 254 color groups. One function alone adapts the illumination, averaging and signal amplification to the current measurement situation. Furthermore, tolerance models and tolerance values can be adjusted individually.

If the sensor recognizes one of the taught colors, the switching state changes via 8 digital outputs. Binary output switching ensures reliable test performance in the face of a discontinuity while providing output of up to 254 color groups.

Equipped with optical fibers, the sensor can also be used in restricted areas as the sensor head requires a minimum of space.



Model	CFO200
Article number	10234671
Object distance	depends on the fiber optics and the ancillary lens used reflected-light optical fiber typ. 2 mm - 25 mm with lens typ. 5 mm - 200 mm <sup>2)</sup>
Light spot diameter	depending on the fiber optics used as well as front lens attachment reflected-light optical fiber typ. dia. 0.6 mm - 20 mm <sup>2)</sup>
Repeatability <sup>1)</sup>	$\Delta E \leq 0.3$
Color distance	$\Delta E \leq 0.6$
Color spaces	XYZ, xyY, L*a*b*, L*u*v*, u'vL*
Averaging	automatic adaption depending on the measurement frequency over max. 200 values
Size of color memory	> 320 colors in non-volatile EEPROM with parameter sets
Measurement frequency	standard 1 kHz; max. 20 kHz (number of colors being taught and the setting for the averaging depend on this)
Temperature drift X,Y	0.1 % / K
Light source	white light LED, AC mode (adjustable or OFF for self-luminous objects, software-switchable)
Type of illumination	via fiber optics
Effect from illumination	automatically adjustable
Ambient light	up to 5000 lux
Alternating light operation	AC: typ. 1 kHz; max. 20 kHz
Power supply	+18 ... 28 VDC
Power consumption	typ. 500 mA
Max. switching current	100 mA
TEACH key/inputs	5 keys and IN0 for externally teaching color reference, tolerance stage and configuring sensor
Outputs	OUT 0 - OUT 7, digital (0V/+Ub), 100 mA max. switching current
Switching state display	visualization with 13 white LEDs
Interface	Ethernet, RS232 and USB process interfaces
Type of connector	to power/PLC: 8-pole flange connector; PLC: 8-pole flange socket (M12A) to PC: 4-pole flange socket (M12D) (Ethernet DHCP-capable)
Connection cable	to power/PLC: art. no. 11234717 / 11234722; to PC: art. no. 11234735 (Ethernet)
Receiver	3-color filter detector (XYZ TRUE COLOR detector, color curve according to CIE1931)
Pulse extension	off by default, typ. 10ms, adjustable > 30 $\mu$ s
Signal amplification	5 stages, automatic
Housing material	Aluminum, anodized black
Operating temperature	-10 ... +55 °C
Storage temperature	-10 ... +85 °C
Protection class	IP65

<sup>1)</sup> Maximum color distance  $\Delta E$  of 1000 successive measurements of the color value of a red and a dark gray reference tile (R = 5%), measured with sensor FAR-TA2.0-2.5-1200-67\* at 1000 Hz and brightness adjustment with a white standard (R=95%)

<sup>2)</sup> Model: FAR-T-A2.0-2.5-1200-67 Reflex

Model: FAD-T-A2.0-2.5-1200-67 Transmitted light

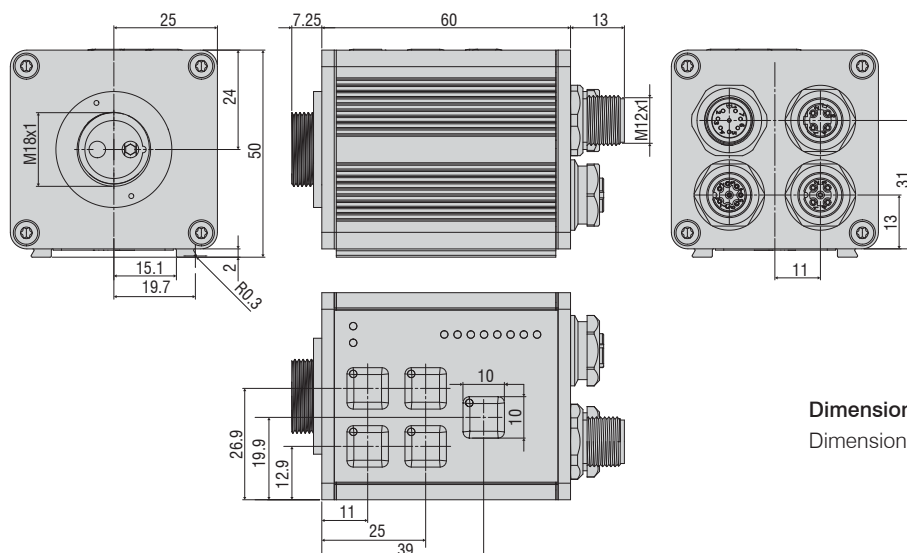

#### Dimensions:

Dimensions in mm, not to scale

### CFO controller

- Compact and robust, direct integration into machine
- Ideal for monitoring of high-speed processes
- High light intensity
- Stable long-term behavior / transmission monitoring



Special fiber optics made from glass for LED Analyzers for high temperature areas (available on request)

### High-quality glass and special fibers for long-life operation

Micro-Epsilon fiber optics feature high processing and transmission quality. Ground and polished end-faces ensure excellent optical integration with adapted sensors. These high-quality, optical glass fibers are extremely robust and ideally suitable for use in harsh ambient conditions.

### Characteristics

- Temperature resistance from -270 °C to +2000 °C
- Flexible and highly flexible with flux
- Cut and polished surfaces
- Wavelength from 180 nm (UV) to 3500 nm (IR)
- Customer-specific modification even for 1 single piece only

Heads for versatile applications

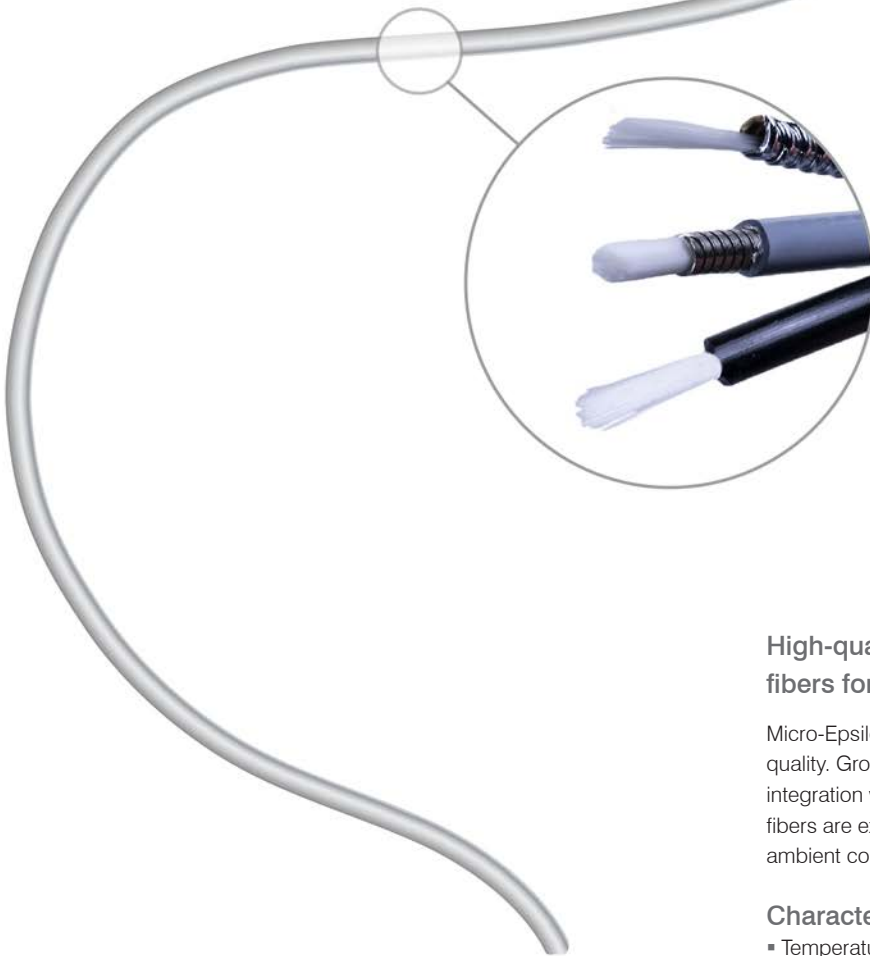

## Functions of the fiber optics



Application instructions on selecting the appropriate function.

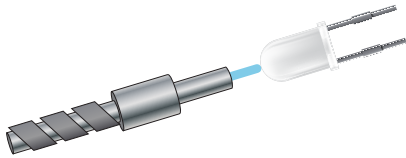

### Receive mode with self-luminous objects

- Max. measurement distance 30 mm
- Recognition of slightest variations in color and intensity
- For color sensor with external illumination
- Ideal for testing LED illumination and self-luminous objects

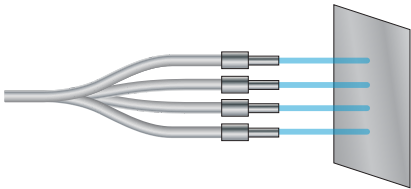

### Available on request

#### Special types for multiple reflex mode

Transmission and receiving fibers are, statistically mixed, guided in two or more separated fiber optics. Therefore, several positions can be detected using only one sensor.

### Available on request

#### Special types for multiple transmitted light mode

The light path of the axially opposing probe head ferrules is interrupted or damped by one or more objects.

Example for a typical LED recognition fiber optics for use with a colorSENSOR CFO	
10814792	<b>FAL-T-C3.0-3,0-1200-67° LED detection special fiber optic cable</b>
Fiber optic connector	FAL = FA adapter, only pen opposite the coding assembled with fibers
Sheathing	T = Silicone-metal hose: very flexible, highly resistant to bending and tension
Fiber bundle	ø 3.0 mm
Optical fiber length	1200 mm
Aperture angle	67°
Temperature range (ferrule)	-10 °C to +80 °C
Temperature range (sheathing)	-40 °C to +180 °C

Example for a special LED detection fiber optic cable for use with a colorCONTROL MFA LED analyzer	
10814868	<b>S-M-C1.0-1,5-1800-67-T250 Single-channel LED recognition for MFA-5</b>
Ferrule	S = ferrule M2.0 (but dimension D 33 mm and dimension E 2.2. mm)
Sheathing	M = metal hose, flexible, protection against mechanical stress, temperature stable up to 300 °C
Fiber bundle	ø 1.5 mm
Optical fiber length	1800 mm
Aperture angle	67°
Temperature range (ferrule M2.0)	-10 °C to +80 °C
Temperature range (ferrule C1.0)	T250 = -40 °C to +250 °C
Temperature range (sheathing)	-40 °C to +300 °C

Please refer to the colorSENSOR catalog for further fiber optic configurations or contact us.

## 1 Function

L for testing self-luminous objects (only receiving fibers assembled)

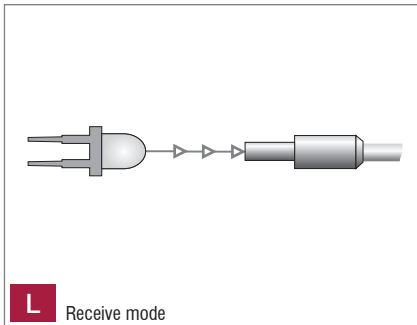

## 2 Sheathing



Please determine the sheathing and the bonding of the fiber optics based on the prevailing environmental conditions and mechanical stress. Please contact us in case of high temperature applications or extreme, mechanical stress.

### Silicone-metal sheath

Metal wire-spiral-reinforced hose with glass-fiber braiding and silicone rubber sheathing <sup>1)</sup>

#### Characteristics:

- Very flexible, ideal for frequent bending
- Highly resistant to bending, tension and torsion
- Temperature-stable from -60 °C to +180 °C
- Liquid-tight

T



### VA stainless-steel sheath

Flexible stainless steel wire-spiral-reinforced hose <sup>1)</sup>

#### Characteristics:

- Flexible
- Protection against mechanical stress
- Temperature-stable to 400 °C
- Stainless

E



### Metal sheath

Flexible brass wire-spiral-reinforced hose, chrome-plated <sup>1)</sup>

#### Characteristics:

- Flexible
- Protection against mechanical stress
- Temperature-stable to 300 °C

M



### Special models

#### Fiber optics with increased vibration protection - VS option

Fiber optics can be manufactured with increased vibration protection for use with mechanical loads such as shock, acceleration, and movement. This special treatment minimizes friction between fibers and reduces shocks. The fibers are embedded into a gel cushion.

### Special models

#### Fiber optics with special bonding for high temperatures

Standard bonding is suitable for maximum temperatures up to 80 °C. Special adhesives allow for temperatures of up to 250 °C and even 400 °C. These higher temperature ranges require the use of Type E stainless steel sheathing. With quartz and sapphire fibers and appropriate adhesive, special fiber optics for use in environments up to 2000 °C can be produced.

<sup>1)</sup> Bending radius corresponds to three times the external diameter of the sheath.

<sup>2)</sup> Bending radius corresponds to twice the external diameter of the sheath.

Details about sheath diameters can be found in section 3: (probe head types)

## 3 Probe heads and fiber bundles



Please choose a probe head type and ensure that the probe head is compatible with the fiber bundle diameter  $\varnothing F$  (see 1) and the sheath (see 2).

Standard probe head bonding for -10 °C to +80 °C

Please refer to the technical data for special models (T250, T400).

All details in mm; tolerances: typ.  $\pm 0.1$  mm

Alu ferrules, black anodized

Please contact us if you require other dimensions.

### Detection ranges of the probe heads

Fiber bundle Ø F mm	Working distance mm	Light spot for 67° fiber approx. Ø mm	Light spot for 22° fiber approx. Ø mm
0.6	5	3	3
	10	5	4
	15	8 <sup>1)</sup>	6
	20	12 <sup>1)</sup>	8
1	5	3	3
	10	7	5
	15	11	8 <sup>1)</sup>
	20	15 <sup>1)</sup>	11 <sup>1)</sup>
1.5	5	4	3
	10	7	5
	15	11	8
	20	19 <sup>1)</sup>	11
2.5	5	5	4
	10	10	8
	15	13	10
	20	19 <sup>1)</sup>	13
3	5	8	5
	10	12	7
	15	15	10
	20	18 <sup>1)</sup>	13

Typical values determined with colorSENSOR CFO200; <sup>1)</sup> only feasible under certain conditions

#### C Type C ferrule, stainless steel

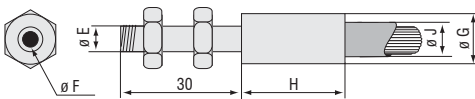

Ø F	Model	E	Ø G	H	P	Ø J	M	T
1.0	C 1.0	M4	6	13	5	5	4.4	
2.5	C 2.0	M6	8	15	6	6	5.8	
3	C 3.0	M10	11	12	7	7	7.5	

#### M Type M ferrule, aluminum / stainless steel

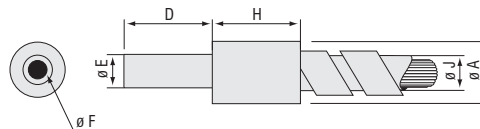

Ø F	Model	Ø A	D	Ø E	H	Ø J	M	T	Ferrule
0.6	M 1.1	6	30	1	10	5	4.4		stainless steel
0.6	M 1.2	6	10	1	10	5	4.4		stainless steel
1	M 2.0	6	10	2	10	5	4.4		Alu
2.5	M 3.0	7	12	4	12	6	5.8		Alu
3.5	M 4.0	9	12	6	12	7	7.5		Alu

Larger fiber cross-sections are possible

## 4 Length



Standard lengths are: 600\*, 1200\*, 1800 and 2400 mm.

\*Bearing types

Length tolerance typ.: ± 4 %

Cable lengths of up to 30 m can be supplied on request.

## 5 Aperture angle

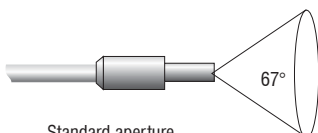

Standard aperture angle 67°

### Available on request

Pressure-proof feed-through up to 10 bar <sup>2) 3)</sup>

Housing feed-through

Adapter for optical fiber FA on FA

Suitable for use in vacuum

Suitable for use with drag cable

Vibration protection

Tomography

Single channel

Multi-channel

Adaption for C-mount lenses

Special fiber optics according to customer requirements/drawing

<sup>2)</sup> in combination with FAD-X-FAD adapter for optical fiber

<sup>3)</sup> Also suitable for use in vacuum up to 10<sup>-5</sup>



- *Inline color measurement*
- *Non-contact operation*
- *Measurement accuracy is  $\Delta E \leq 0.08$  (sample-related)*
- *Measurement frequency from 25 Hz to 2000 Hz*
- *Ethernet/EtherCAT, RS422, Digital I/O*
- *Web browser operation*

#### Features:

- Light source: adjustable standard illuminant and observer
- Color spaces (adjustable) : XYZ; L\*a\*b\*; L\* u\* v\*; L\*c\*h
- Color recognition from a taught reference list
- White/black reference comparison (via browser and keys on the device)
- Inline quality assurance and continuous documentation
- Spectral evaluation of the illumination spectrum
- Easy parameter setup via web application

The colorCONTROL ACS7000 inline color measuring system recognizes colors not just by comparing them to reference values, but also by using their coordinates in the respective color space to ensure unique identification. Due to its very high measurement speeds, the colorCONTROL ACS7000 is suitable for applications where colors and self-luminous objects have to be inspected on-the-fly and to very high accuracies. Due to the extremely high measurement accuracy, the system is also applied in laboratories.

#### Measuring principle

The spectral procedure is the most accurate method of color measurement. First, the sample is illuminated with a homogeneous white LED light. The spectrum of the reflected light is then calculated with a white reference. Then the coordinates in the CIE-XYZ color system are determined for all wavelengths of visible light (390 to 780 nm) and output in the desired color space. The controller takes into account different observation conditions such as the type of light (illuminant) and standard observer.

#### Function

Three operating modes are possible with the colorCONTROL ACS7000: In the first mode, the color distance  $\Delta E$  is measured for reference. The system operates with up to 15 taught values. The second mode determines and outputs the reflectivity spectrum of the sample. The third mode determines color coordinates and displays these in the desired color space. For quality inspection purposes, a trend analysis can be performed over any time period via L\*a\*b\*; XYZ or L\*c\*h color values.

All modes support measurement speeds up to 2 kHz. Operation and display are performed via a web interface. Light/dark correction can also be carried out via buttons on the controller or through the user interface. Ethernet/EtherCAT, RS422 and digital I/Os are available for data output.

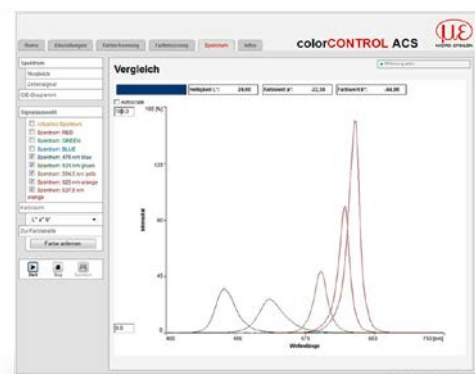

Controller	colorCONTROL ACS7000
Article number	11104174
Spectral measuring range	390 - 780 nm
Measuring range reflectivity	0 - 200 %R
Output values	L*a*b*, L*u*v*, L*c*h°, XYZ, ΔE, spectrum
Illuminants	A, C, D65, D50, D75, E, F4, F7, F11, Off
Standard observer	2°, 10°
Distance models for color recognition	Sphere (ΔE), cylinder (ΔL*, Δa*b*), box (ΔL*, Δa*, Δb*), with individual tolerance parameters for every color taught
Color resolution	0.01 ΔE
Spectral resolution	5 nm
Measuring frequency	25 - 2000 Hz (internal spectrum, signal averaging and data reduction are possible)
Temperature stability	<0.1 ΔE/°C
Light source	LED, 390 - 780 nm
Repeatability of the measurements of a device <sup>1)</sup>	<0.03 (mean); <0.08 (max) ΔE
Housing dimensions	210 x 120 x 90 mm (W x H x D)
Weight	1.8 kg
Protection class	IP40
Operating temperature	0 ... +45 °C
Storage temperature	-20 ... +70 °C
Inputs / Outputs:	4 color detection switching outputs (4 individual colors or 15 colors binary or {ΔE, ΔL* Δa*, Δb*} for one color) 1 Switching output, synchronization 1 Switching input, synchronization 1 Switching output, measurement error
Interfaces	Ethernet/EtherCAT (DHCP-enabled) RS422 (USB via RS422 adapter is possible)
Connection for fiber optics	Illumination: 7mm ferrule with M18 cap (union) nut (analogous to MICRO-EPSILON Eltrotec Fasop system) Measurement: DIN fiber connector
Connection cable	To power supply: Art. No. 11234222 / to PLC: Art. No. 11234223 / to synchronization: Art. No. 11234091 / to PC: Art. No. 11294232 (Ethernet/EtherCAT); 11234224 or 11234230 (RS422)
Additional data processing	Internal calculation of spectral characteristics, color valence calculations, color space transformations, ΔE calculations, and tolerance settings of the upper and lower thresholds for the color values
Connection to software	Control and configuration via integrated Web server or via terminal with commands Visualization of spectral characteristics and temporal sequence of the color values and color differences
Power supply	24 VDC ±15 % 1000 mA
Service life of the light source	>20000 h when operated at 25 °C

<sup>1)</sup> Medium or maximum color distance ΔE of 1000 successive measurements of the color value (mean) of a light gray reference tile (R = 61%), measured with sensor FCS-T-ACS1-30/0-50-1200 at 200Hz and maximum illumination brightness

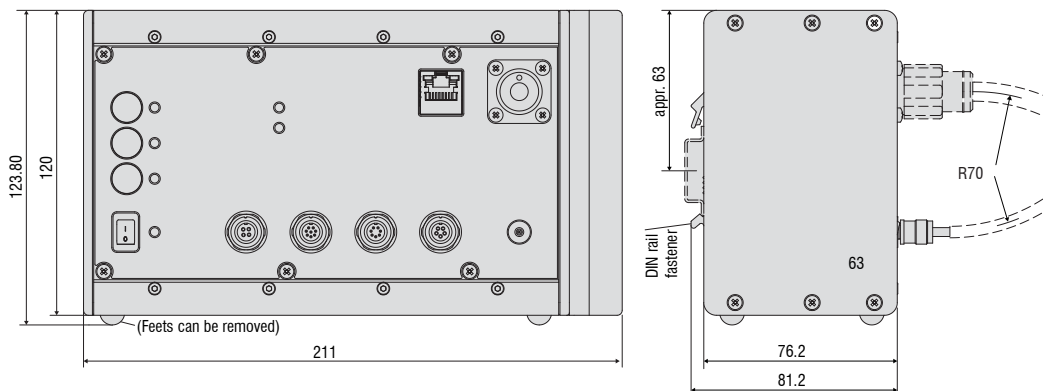



- Measuring self-luminous objects using the colorCONTROL ACS7000
- Measurement distance: max. 200 mm
- Measurement spot:  $\varnothing 5 / \varnothing 9$  mm

The ACS3 transmission sensor is applied for measurements of self-luminous objects and objects illuminated from behind such as film, glass and Plexiglas®. The color of self-luminous objects can be detected as well for which only the receiver unit is required.

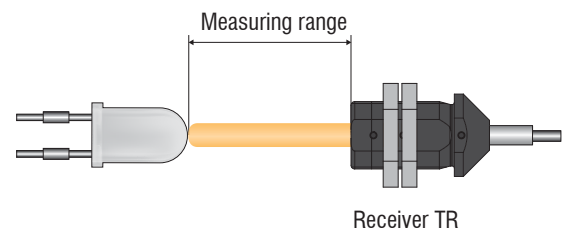



Fiber-optic sensor FCS-T-	ACS3-TR5-200-1200	ACS3-TR9-200-1200
Article number	10824411	10824412
Measurement geometry (illumination : receiver)	Receiver	Receiver
Measuring spot diameter	5 mm for <100 mm <sup>1)</sup>	9 mm for <200 mm <sup>1)</sup>
Optimal measurement distance	10 ... 100 mm	10 ... 200 mm
Permissible measurement distance	10 ... 200 mm	10 ... 300 mm
Distance tolerance <sup>2)</sup>	<0.01 $\Delta E/mm$ <sup>3)</sup>	<0.01 $\Delta E/mm$ <sup>3)</sup>
Tilt angle tolerance <sup>2)</sup>	<0.05 $\Delta E/^\circ$	<0.05 $\Delta E/^\circ$
Ambient light tolerance at max. LED performance	<0.05 $\Delta E/1000$ lux	<0.05 $\Delta E/1000$ lux
Dimensions	$\varnothing 22 \times 40$ mm	$\varnothing 22 \times 40$ mm
Weight (sensor incl. optical fiber)	70 g	70 g
Length of the optical fiber/sensor cable (optical-fiber cable)	1.2 m (max 30 m)	1.2 m (max 30 m)
Bending radius sensor cable	70 mm	70 mm
Protection class	IP64	IP64
Operating temperature	-20 ... +50 °C	-20 ... +50 °C
Storage temperature	-20 ... +50 °C	-20 ... +50 °C
Shock resistance	DIN EN 60068-2-29; 15 g, 6 ms	
Vibration resistance	DIN EN 60068-2-6; 2 g / 10 Hz ... 500 Hz	

<sup>1)</sup> Measurement spot diverges with increasing distance between receiver and target

<sup>2)</sup> Tilt angle tolerance and distance tolerance were determined in transmission with different color glass filters (thickness 2.5mm, refraction index 1.5). When measuring the illumination (only receiver), these were determined with uniformly illuminated (Lambertian) diffuser by tilting the transmitter towards the receiver.

<sup>3)</sup> When using it as receiver sensor for illumination measurement

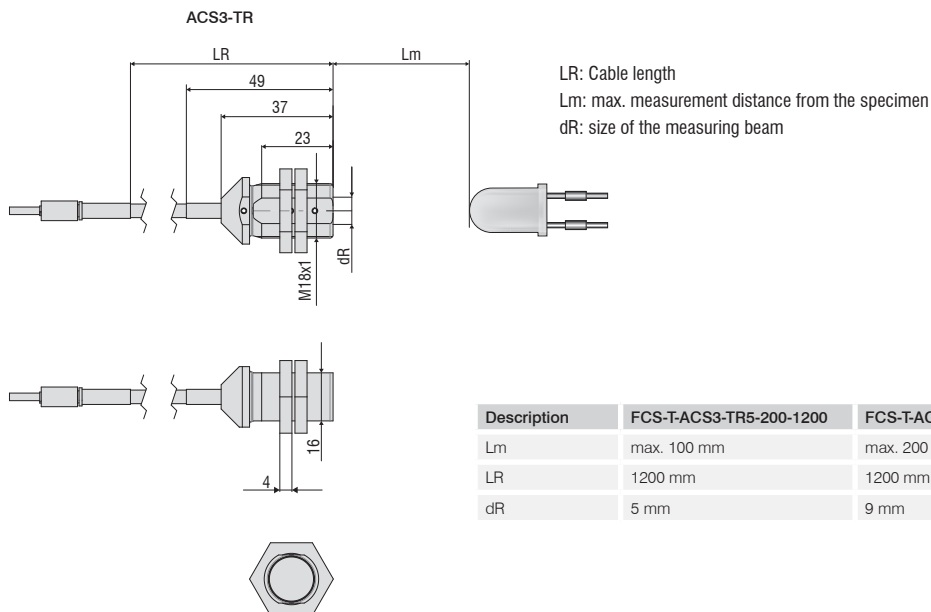

**colorCONTROL MFA Accessory**

Art. No.	Description	suitable for:
10814105	POF-2.2mm fiber optics	colorCONTROL MFA
11251112	Fiber-optic thread fitting; M4	POF-2,2
11251113	Mountable lens 6 mm	Fiber-optic thread fitting; M4
11253931	Fiber-optic thread fitting; 3mm lens; M4	POF-2,2
11254108	Fiber-optic thread fitting; 90° lens, M5	POF-2,2
11253959	Reducing adapter 2.2/1 mm POF; 2 pc.	colorCONTROL MFA for use of POF-1 mm
10813842	POF-1mm fiber optics	colorCONTROL MFA in connection with the reducing adapter 2.2/1 mm POF
11253906	Guide sleeve 1 mm	POF-1 mm
10824431	Guide sleeve 1 mm x 50 mm	POF-1 mm
11234517	Cutting knife for POF fiber optics	POF optical fiber
11294205	CAB-M9-2P-co-fm-straight; 2m-PUR; open ends	colorCONTROL MFA-5 (power)
11294206	CAB-M9-2P-co-fm-straight; 5m-PUR; open ends	colorCONTROL MFA-5 (power)
11234094	CAB-M9-4P-co-straight; 2m-PVC; USB	colorCONTROL MFA-5 (USB)
11234102	CAB-M9-4P-co-straight; 5m-PVC; USB	colorCONTROL MFA-5 (USB)
11234095	CAB-M5-4P-co-straight; 2m-PUR; RS232	colorCONTROL MFA-5 (RS232)
11234103	CAB-M5-4P-co-straight; 5m-PUR; RS232	colorCONTROL MFA-5 (RS232)
11294243	Assembly kit MFA-10	colorCONTROL MFA-5 + MFA-5-M
11294244	Assembly kit MFA-15	colorCONTROL MFA-5 + 2 x MFA-5-M
11294245	Assembly kit MFA-20	colorCONTROL MFA-5 + 3 x MFA-5-M
11294203	CAB-socket board-6P-co-fm-straight; 2m-PVC; 2P-open ends	colorCONTROL MFA-5-P (power)
11294054	CAB-socket board-6P-co-fm-straight; 1m-PVC; USB	colorCONTROL MFA-5-P (USB and power)
11294204	CAB-socket board-4P-co-fm-straight; 2.5m-PVC; RS232	colorCONTROL MFA-5-P (RS232)

**colorSENSOR Accessory**

Art. No.	Description	suitable for:
10815532	CFS5-22-1000 receiver sensor	colorSENSOR CFO
11234717	CAB-M12-8P-co-fm-straight; 2m-PUR; open ends	colorSENSOR CFO (SYS; power and PLC)
11234718	CAB-M12-8P-co-straight; 5m-PUR; open ends	colorSENSOR CFO (SYS; power and PLC)
11234722	CAB-M12-8P-co-straight; 2m-PUR; open ends	colorSENSOR CFO200 (digital I/O; PLC)
11234723	CAB-M12-8P-co-straight; 5m-PUR; open ends	colorSENSOR CFO200 (digital I/O; PLC)
11234735	CAB-M12-4P-St-ge; 2m-PUR-Cat5e; RJ45-Eth	colorSENSOR CFO (Ethernet)
11234736	CAB-M12-4P-St-ge; 2m-PUR-Cat5e; RJ45-Eth	colorSENSOR CFO (Ethernet)
11234713	CFO mounting adapter	colorSENSOR CFO
11234762	CFO DIN rail mounting kit	colorSENSOR CFO
11234763	CFO DIN rail mounting adapter	colorSENSOR CFO
11234694	White standard 30 mm zenith	colorSENSOR and colorCONTROL
11234695	White standard 30 mm zenith calibrated	colorSENSOR and colorCONTROL
2420065	PS2030 power supply 24V/24W/ 1A; 2m-PVC; terminal-2P-co-fm-straight	Power supply of all sensors with 24 VDC

**colorCONTROL ACS accessories**

Art. No.	Description	suitable for:
11234694	White standard 30 mm zenith	colorSENSOR and colorCONTROL
11234695	White standard 30 mm zenith	colorSENSOR and colorCONTROL
11234696	White standard 5x5cm Zenith	colorSENSOR and colorCONTROL
11234697	White standard 5x5cm Zenith calibrated	colorSENSOR and colorCONTROL
11234222	CAB-M9-4P-co-straight; 2m-PUR; open ends	colorCONTROL ACS7000 (power)
11234225	CAB-M9-4P-co-straight; 5m-PUR; open ends	colorCONTROL ACS7000 (power)
11234091	CAB-M9-8P-co-straight; 2m-PUR; open ends	colorCONTROL ACS7000 (digital I/O, Sync.)
11234099	CAB-M9-8P-co-straight; 5m-PUR; open ends	colorCONTROL ACS7000 (digital I/O, Sync.)
11234223	CAB-M9-7P-co-straight; 2m-PUR; open ends	colorCONTROL ACS7000 (Color Out)
11234226	CAB-M9-7P-co-straight; 5m-PUR; open ends	colorCONTROL ACS7000 (Color Out)
11294232	CAB-RJ45-Eth; 2m-PVC-Cat5e; RJ45-Eth	colorCONTROL ACS7000 (Ether-net/-CAT)
11293257	CAB-RJ45-Eth; 5m-PVC-Cat5e; RJ45-Eth	colorCONTROL ACS7000 (Ether-net/-CAT)
11294277	CAB-RJ45-Eth-Cross; 3m-PVC-Cat5e; RJ45-Eth	colorCONTROL ACS7000 (Ether-net/-CAT)
11293258	CAB-RJ45-Eth-Cross; 5m-PVC-Cat5e; RJ45-Eth	colorCONTROL ACS7000 (Ether-net/-CAT)
11234224	CAB-M9-5P-co-straight; 2m-PVC-RS422; open ends	colorCONTROL ACS7000 (RS422)
11234227	CAB-M9-5P-co-straight; 5m-PVC-RS422; open ends	colorCONTROL ACS7000 (RS422)
11234230	CAB-M9-5P-co-straight; 2m-PVC-RS422; Sub-D-15P-co-straight	colorCONTROL ACS7000 (IF2008)
11234231	CAB-M9-5P-co-straight; 5m-PVC-RS422; Sub-D-15P-co-straight	colorCONTROL ACS7000 (IF2008)
2213017	IF2008 Interface card RS422 / PCI-card	colorCONTROL ACS7000 (RS422/PC)
2213025	IF2001/USB 1-channel RS422/USB converter	colorCONTROL ACS7000
10824338	FCS-ACS1-30/0 tactile adapter	FCS-X-ACS1-30/0-50-XXXX
10824424	FCS-ACS adapter TT-TR	all ACS sensor heads (connection illumination into receiving fibers)
10824804	FCS-ACS3 90° attachment	FCS-X-ACS3 TT and TR
10824414	FCS-ACS3-200 mounting rail	FCS-X-ACS3
10824423	FCS-ACS3 mounting adapter 50 mm	FCS-ACS3-200 mounting rail
10824422	FCS-ACS3 mounting adapter 150 mm	FCS-ACS3-200 mounting rail
10824708	FCS-ACS1/ILD1420 adapter plate angled	FCS-X-ACS1 distance readjustment with ILD1420
10824709	FCS-ACS2/ILD1420 adapter plate angled	FCS-X-ACS2 distance readjustment with ILD1420
10824710	FCS-ACS2/ILD1420 adapter plate angled	FCS-X-ACS2 distance readjustment with ILD1420
2420065	PS2030 power supply 24V/24W/ 1A; 2m-PVC; terminal-2P-co-fm-straight	CAB-M9-4P-co-straight; Xm-PUR; open ends (power)

**Pin assignment****CAB-M9-4P-co-straight; Xm-PUR;****open ends**

(art.no.: 11234222; 11234225)

Connection cable Power

(max. length 10 m, PUR sheath)

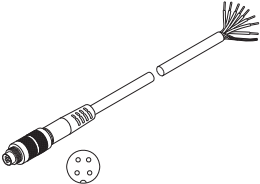

Pin	Color	ACS7000
1	white	n. c.
2	brown	+24V DC (±15%)
3	black	n. c.
4	blue	GND (0V)

**CAB-M8-4P-fm-co-straight; Xm-PUR;****open ends**

(art.no.: 11234305; 11234306)

Connection cable to Power/PLC

(max. length. 5 m, PUR sheath)

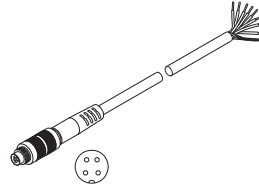

Pin	Color	MFA-1
1	brown	+ 24VDC
2	white	External Teach
3	blue	GND
4	black	NPN/ PNP

**CAB-M12-8P-co-fm-straight; Xm-PUR;****open ends**

(Art.-No.: 11234717; 11234718)

Connection cable SYS; Power and PLC

(max. length 10 m, PUR sheath)

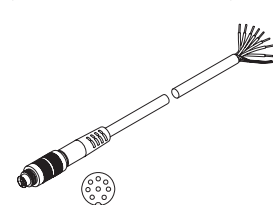

Pin	Color	CFO100/200
1	white	IN0
2	brown	+UB
3	green	TX
4	yellow	RX
5	gray	OUT0
6	pink	OUT1
7	blue	GND
8	red	OUT2

**CAB-M9-2P-co-fm-Straight; Xm-PUR;****open ends**

(Art.-No.: 11294205; 11294206)

Connection cable Power

(max. length 10 m, PUR sheath)

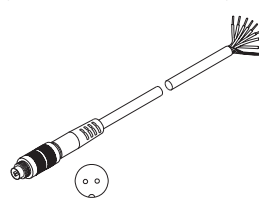

Pin	Color	MFA-5
1	white	+24 VDC
2	brown	GND

## Sensors and Systems from Micro-Epsilon



Sensors and systems for displacement, distance and position



Sensors and measurement devices for non-contact temperature measurement



Measuring and inspection systems for metal strips, plastics and rubber



Optical micrometers and fiber optics, measuring and test amplifiers



Color recognition sensors, LED analyzers and inline color spectrometers



3D measurement technology for dimensional testing and surface inspection