

FlexiForce[®]

Standard Model A301

The FlexiForce A301 is our smallest standard piezoresistive force sensor. The A301 design is optimized for high volume manufacturing and is ideal for embedding into products and applications. This sensor is available in low and high quantities off-the-shelf, ideal for an easy proof of concept. The A301 sensor is designed to use with your own electronics or multimeter.

Actual size of sensor

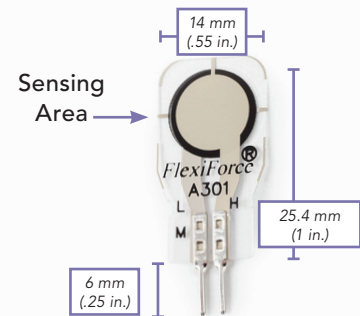

BENEFITS

- Small size is ideal for prototyping and integration
- Thin and flexible
- Easy to use

PHYSICAL PROPERTIES

Thickness	0.203 mm (0.008 in.)
Length	25.4 mm (1 in.)*
Width	14 mm (0.55 in.)
Sensing Area	9.53 mm (0.375 in.) diameter
Connector	2-pin Male Square Pin
Substrate	Polyester (ex: Mylar)
Pin Spacing	2.54 mm (0.1 in.)

✓ **ROHS COMPLIANT**

* Length does not include pins, please add approximately 6mm (0.25 in.) for pin length for a total length of approximately 32 mm (1.25 in.).

STANDARD FORCE RANGES

(as tested with circuit shown below)

- 4.4 N (0 - 1 lb)
- 111 N (0 - 25 lb)
- 445 N (0 - 100 lb)

In order to measure higher forces, apply a lower drive voltage (-0.5 V, -0.10 V, etc.) and reduce the resistance of the feedback resistor (1kΩ min.) To measure lower forces, apply a higher drive voltage and increase the resistance of the feedback resistor.

Sensor output is a function of many variables, including interface materials. Therefore, Tekscan recommends the user calibrate each sensor for the application. The graph below is an illustration of how a sensor can be used to measure varying force ranges by changing the feedback resistor (the graph below should not be used as a calibration chart).

Recommended Circuit

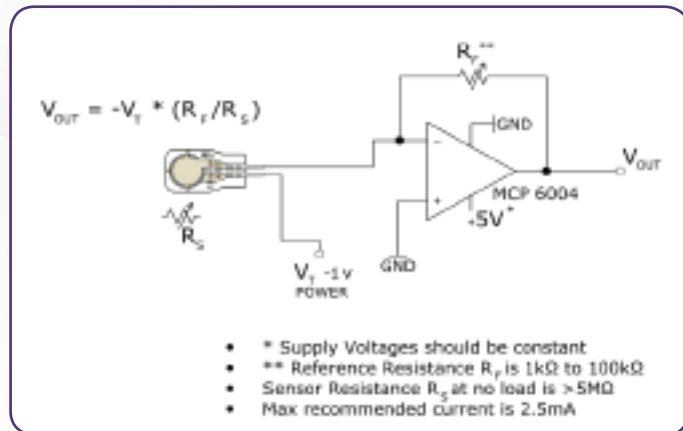

	Typical Performance	Evaluation Conditions
Linearity (Error)	< ±3%	Line drawn from 0 to 50% load
Repeatability	< ±2.5% of full scale	Conditioned sensor, 80% of full force applied
Hysteresis	< 4.5 % of full scale	Conditioned sensor, 80% of full force applied
Drift	< 5% per logarithmic time scale	Constant load of 111 N (25 lb)
Response Time	< 5μsec	Impact load, output recorded on oscilloscope
Operating Temperature	-40°C - 60°C (-40°F - 140°F)	Time required for the sensor to respond to an input force

- Force reading change per degree of temperature change = 0.36%/°C (±0.2%/°F)



ISO 9001 & 13485



PURCHASE TODAY ONLINE AT
WWW.TEKSCAN.COM/STORE