

VIC-3D + BLUE HAWK

Simple. Powerful. Fully-Integrated

3D digital image correlation is a technique that relies on a precise relationship between two cameras. For decades, researchers have spent countless hours in the pursuit of the perfect stereo angle and exact focus. In a growing number of applications, repetitive testing is required, and researchers are calling on DIC to provide precise, non-contact strain and deformation measurements in successive, identical tests. In these scenarios, valuable testing time is lost to necessary but laborious camera setup and adjustments. After an extensive testing and iterative design process, we are proud to introduce the Blue Hawk System.



OTHER BLUE HAWK FEATURES

- Compact and robust design for excellent calibration disturbance resistance
- Adjustable FOV range from 40 to 400 mm with excellent measurement resolution
- Integrated high-powered blue LED illumination with polarization filter (suitable for fluorescence technique)
- Interchangeable lenses & baseline steps for multiple field-of-view (FOV) configurations
- Suitable for real-time full-field data display and/or virtual strain gauge or extensometer output

Compared to the variety of fixed field-of-view (FOV) DIC options available, VIC-3D with the Blue Hawk system offers more adjustability without compromising convenience, so researchers can measure a wide variety of applications with minimal adjustment. Once the FOV preference is set (with easy lens/baseline adjustments to pre-determined fixed locations), the system can be used repeatedly with the same stereo calibration model. This combination of precision and repeatability produces highly accurate results with an unmatched level of convenience.



Rigid Stereo Calibration

The Blue Hawk is designed for repetitive DIC testing for fixed FOV applications. Due to its super-rigid architecture, the system can be calibrated once and then used for multiple DIC tests at various locations over long periods of time. Need to set up the system for more testing with a different FOV? Not a problem with an easy-change optical procedure that also allows the base line to be adjusted to 4 different positions.

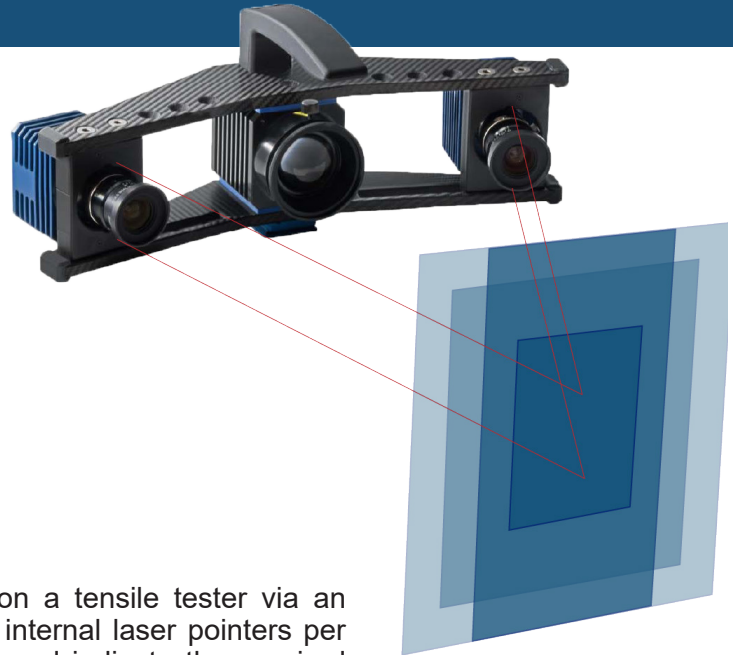

Integrated Laser Alignment

The Blue Hawk system can be mounted directly on a tensile tester via an adjustable arm, or it can be used on a tripod. Two internal laser pointers per camera assist with alignment to the specimen axis and indicate the required working distance. Alignment is performed using the tripod head or a levelling adapter. The working distance is preset using the horizontal beam, and focus is fine-tuned using a linear stage. What sets the Blue Hawk system apart is the sheer range of setup possibilities.

FOV for 24.6 Mpx sensor				Focal length of lenses [mm]					
Base line	Stereo Angle	TWD [mm]	FOV [mm]	60	50 ²	45	40 ¹	35	25
283 mm (max.)	20° (min.)	800	Height	162	202	228	259	302	420
			Width	140	175	197	224	261	363
	25° factory setting	638	Height	120	155	176	202	235	340
			Width	104	134	152	175	203	294
148 mm (min.)	25° factory setting	334	Height	45	65	76	90	108	160
			Width	39	56	66	78	93	138
	30° (max.)	276	Height	30	46	56	68	82	130
			Width	26	40	48	59	71	112

¹ Standard package for tensile sample is with 40 mm focal length ² For small FOV 60 mm lens is recommend

638 mm (min. 528 mm / max. 800 mm)

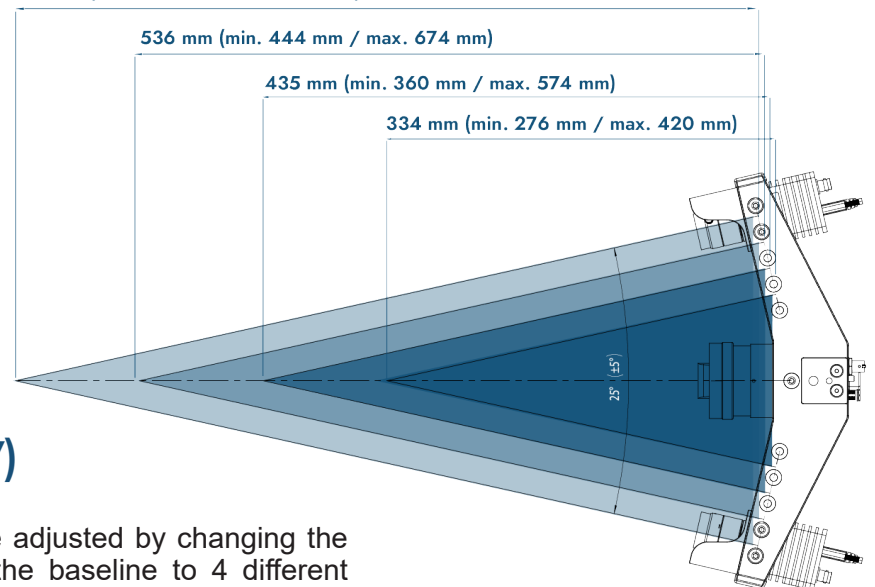

Adjustable Field-of-View (FOV)

The field-of-view of the Blue Hawk can be adjusted by changing the focal length of the lens and by moving the baseline to 4 different positions. The stereo angle is pre-set at 25° and can be fine adjusted by +/- 5° (min. 20°, max. 30°).

The resulting FOV range is from 40 to 400 mm using the included easily changeable standard lenses. To change the FOV, simply follow these four steps: a) change the lenses, b) move the cameras to the desired position, c) position the system using the integrated laser alignment tool, and d) perform an automatic stereo calibration using the included VIC-Gimbal.