

Measurement Shaft Kit 10 Nm

Torque Measurement System consisting of:

- Torque measuring shaft with integrated Rotor Antenna
- Evaluation Unit
- Documentation

Measurement System:

- Measuring range: 10 N·m
- Signal resolution: 16 Bit
- Linearity and hysteresis: <0.25%
- Distance rotor to evaluation unit: 0.5 ... 5 mm
- PCM technique
- Maintenance-free
- Integrated Remote Shunt Calibration function



Measurement Shaft Kit 10 Nm

Shaf (MW_10NM):

- Number of channels: 1
- Strain gauge bridge integrated
- Measuring range: 10 N·m
- Signal bandwidth: 0 ... 1 kHz
- Zero and gain drift: $\pm 0.05\%/^{\circ}\text{C}$
- Dimensions: $\varnothing 20$ mm, 120 mm
- Rotational speed range: 0 ... 10,000 1/min
- Temperature range: -10 ... $+55^{\circ}\text{C}$
- Protection class according to EN 60529: Ip42

Evaluation Unit and Antenna (AW_DAnt)

- with integrated PickUp (stator antenna)
- Number of channels: 1
- Analog output voltage: 0 ... ± 10 V / 50 ohms
- Signal bandwidth: 0 ... 1 kHz
- Zero and gain drift: $\pm 0.05\%/^{\circ}\text{C}$
- Supply voltage: 24 VDC $\pm 10\%$, 220 mA
- Connection: D-SUB-9 plug
- Dimensions: 90 x 50 x 22 mm
- Temperature range: -10 ... $+55^{\circ}\text{C}$
- Protection class according to EN 60529: IP42

Measurement Shaft Kit 10 Nm

Cable (VKab_Dana_Kal):

- Cable length: 2 m
- Connector: D-SUB-9 socket
- with integrated button to check the calibration

Included in delivery

- Torque Measuring MW_10NM
- Evaluation Unit AW_DAnt
- Supply and data cable with D-SUB-9 socket
Cable length: 2 m
with integrated button to check the calibration
for systems with analog data output
- Calibration protocol
- Documentation on USB

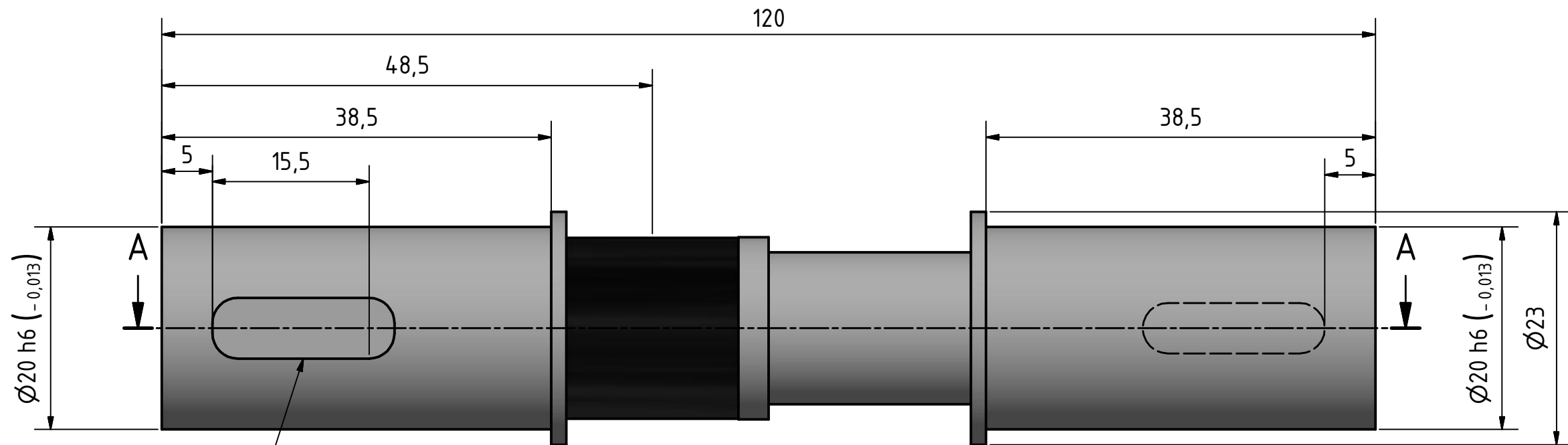

Passfeder DIN 6885 - A 6 x 6 x 18

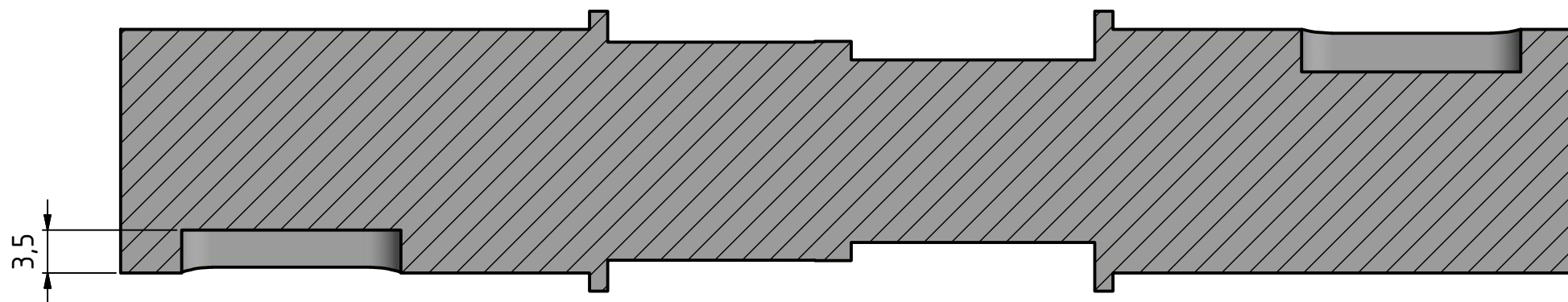

		Allg.-Toleranzen ISO 2768-mK	Oberfläche ISO 1302	Werkstoff: Manner Messstahl	
"Schutzvermerk nach DIN 34 beachten" Werkstückkanten DIN 6784		Form- u. Lagef. DIN ISO 1101		HSMW-10	
		Datum	Name		
		Gezeichnet	30.10.2019	Lander	
		Kontrolliert			
		Norm			
				10 N·m	1
					A3
Status	Änderungen	Datum	Name	www.sensortelemetrie.de	