

Figure 1: Accuband C965 Width Gage

1 DESCRIPTION

The ACCUBAND C965 Width Gage is a non-contact optoelectronic instrument which measures the width of a metal strip during both rough and finish rolling. Output data includes strip width and centerline deviation.

Inside the scanner two CCD cameras, custom built by KELK, are mounted on a beam, a fixed distance apart and above the moving strip. Each camera scans a narrow 2048 pixel line across the path of the strip, accurately locating the angular positions of the two edges. The edge data is then processed to calculate the strip width and centerline deviation. Advanced algorithms provide accurate edge detection and allow for limited temperature gradients, scale and steam.

The scan rate is optimized for each application, and held constant over a wide strip temperature range. Triangulation techniques compensate for changes in edge locations due to strip hop, tilt, wavy edge, or variations in material thickness. A standard MODBUS/TCP communications protocol provides access to all process data and gage status information.

2 APPLICATIONS

The ACCUBAND C965 Width Gage is used in hot strip / plate mills, at:

- **Roughing Mill Entry or Exit** as an integral part of Automatic Width Control system
- **Roughing Mill Exit** or **Crop Shear Entry** as part of the Accuband Crop Optimization System
- **Between Finishing Stands** for inter-stand AGC, stripsteering, and necking control
- **Finishing Mill Exit** for width measurement input to the Laminar Cooling Model
- **Coiler Entry** for confirmation of coiled width

3 STANDARD FEATURES

- Accurate and reliable measurement of width, centerline and edge heights.
- Able to compensate for limited amounts of scale, steam, spray, and material hop, tilt, lateral movement, and edge temperature gradients
- Fast head end response
- Advanced gain control allows for dynamic signal optimization based on material temperature
- Extensive environmental protection ensures reliable measurement, protects the gage from shock loading and minimizes maintenance requirements, thereby eliminating the need for an expensive gage house
- An air nozzle designed to keep the scanner windows clean and assists in clearing steam and spray from the measurement field of view
- A dynamic calibrator allows rapid confirmation of proper operation. A calibrator mask is provided with a certificate of accuracy traceable to the U.S. National Institute of Standards and Technology
- A calibrator carrier, used together with a laser aiming device in the scanner, allows quick and easy positioning of the calibrator below the scanner
- A comprehensive diagnostic system monitors the operation of the width gage and provides status signals to the mill host computer. Additional diagnostics can be accessed by service personnel through a maintenance interface accessible over an Ethernet network.
- Conversion of “hot width” to “cold width” values of strip measurement is possible via up to 63 user-entered expansion curves (requires temperature input)
- Java based Maintenance Interface is accessible from any web browser connected via Ethernet network

4 SYSTEM CONFIGURATION

ACCUBAND C965 Width Gage is available in two models:

- **C965-A**
Operates on radiant energy (IR) for strip edge temperatures of 600 °C to 1300 °C (1112 °F to 2372 °F).
- **C965-B**
Views the strip as a shadow over a LED backlight mounted below the roll table.
This model is required when strip edge temperatures fall below 600 °C (1112 °F).

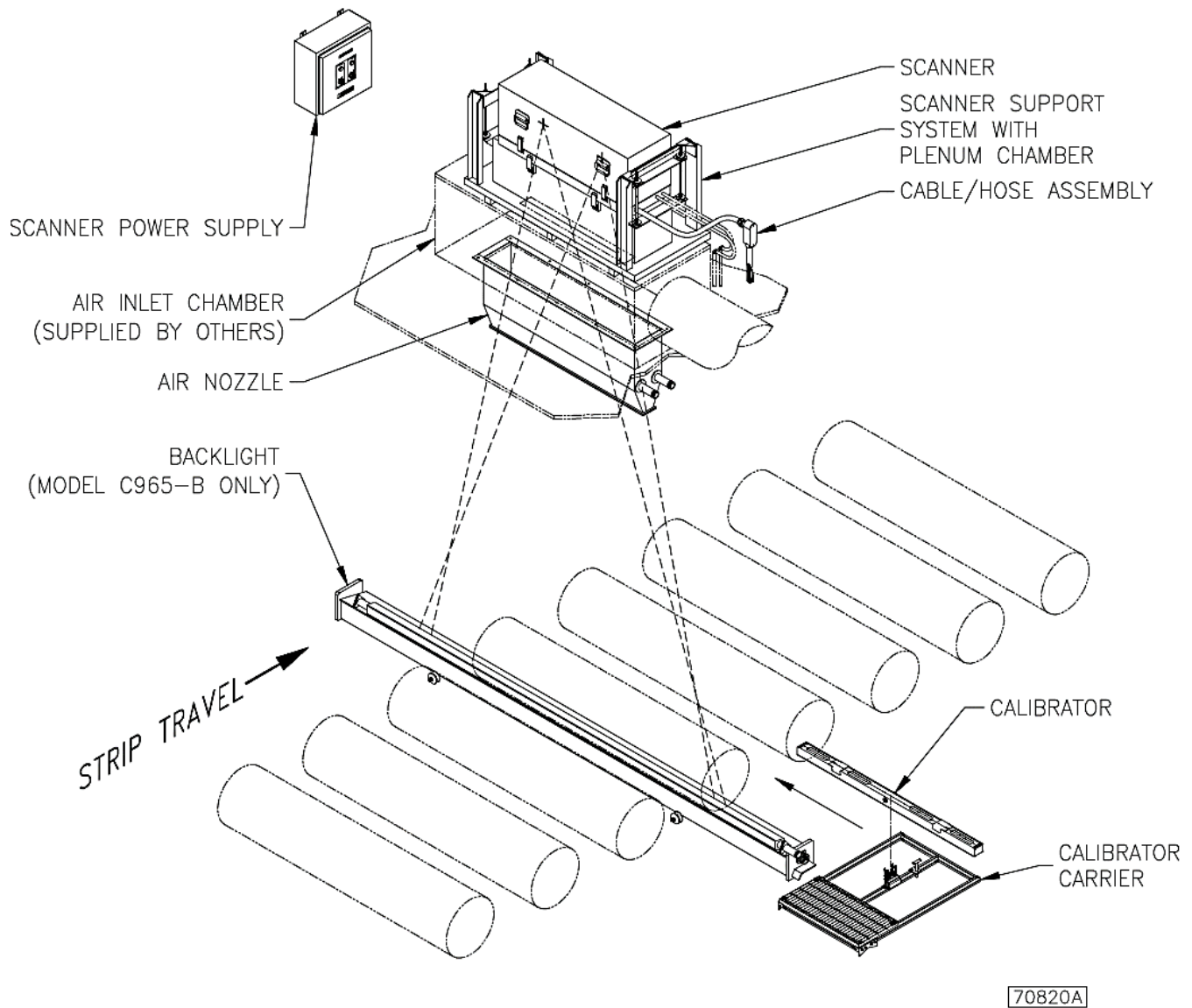

Figure 2: Accuband C965 Width Gage Full System Setup

4.1 SYSTEM COMPONENTS

4.1.1 SCANNER ASSEMBLY

The scanner contains two CCD cameras and their associated processor, mounted above the strip on a vibration-isolated frame and housed in a water-cooled, sealed enclosure (NEMA 4/IP65) that is supported by a heavy-duty shock and vibration-isolating suspension system. A scanner cable hose assembly with a length of 15 m (49 ft.) is provided. The scanner is also supplied with an Air Nozzle, which helps to keep the camera windows and field of view clear of steam and dust, and Scanner Power Supply. The Modular construction allows for rapid on-site replacement of major components.

The scanner is mounted above the strip at a height based on the required field of view. A typical mounting height for a strip 2100 mm (83 in) wide is between 4 to 5 meters (13 to 16 ft). With three lens options available the installation height may be modified to accommodate an existing structure.

SCANNER SUPPORT SYSTEM WITH PLENUM CHAMBER

The scanner support system is mounted on a user supplied platform. The plenum chamber is attached to the scanner support system via a heavy-duty shock and vibration-isolating suspension. The plenum chamber supports the scanner and provides a zone of clean, still air, to keep the camera windows clean.

The frame which supports the scanner and plenum chamber can be optionally supplied with wheels, so the Scanner can be moved, on user-supplied rails, to an off-line position for calibration and maintenance.

AIR NOZZLE

Using compressed air, the stainless steel air nozzle works with the plenum chamber to keep the camera windows clean. Air moving through the air nozzle causes a Venturi effect forcing air in the plenum chamber to be pulled down towards the air nozzle. The movement of air away from the scanner helps to keep the camera windows and field of view clear of steam and dust. The air nozzle can be operated over a wide range of air pressures to suit local environmental conditions. The air nozzle is located below the plenum chamber, fixed to the underside of the user-supplied platform.

SCANNER POWER SUPPLY

The scanner power supply provides DC power to the scanner electronics. It is housed in a wall-mounted NEMA 4/IP65 cabinet and also serves as the junction box for wiring between the scanner, optional KELK equipment and the mill control system. In a typical installation, the scanner power supply is installed in an accessible location within 11 m (36 ft) of the scanner.

4.1.2 CALIBRATOR AND CALIBRATOR CARRIER

The calibrator is used to calibrate the width gage after installation and following any service work, if necessary, to assure the user of optimum performance. The calibrator also provides a quick, easy, and reliable means of checking gage accuracy. The calibrator is designed to simulate the dynamic behavior of a metal strip during rolling by oscillating about the horizontal.

A mask with four backlit openings provides symmetrically spaced illuminated edges in accurately known positions. The mask is supplied with a Certificate of Accuracy traceable to the U.S. National Institute of Standards and Technology.

The calibrator carrier is a portable support platform for the calibrator. Together with the laser aiming device located in the scanner, correct calibrator positioning can be accomplished within seconds.

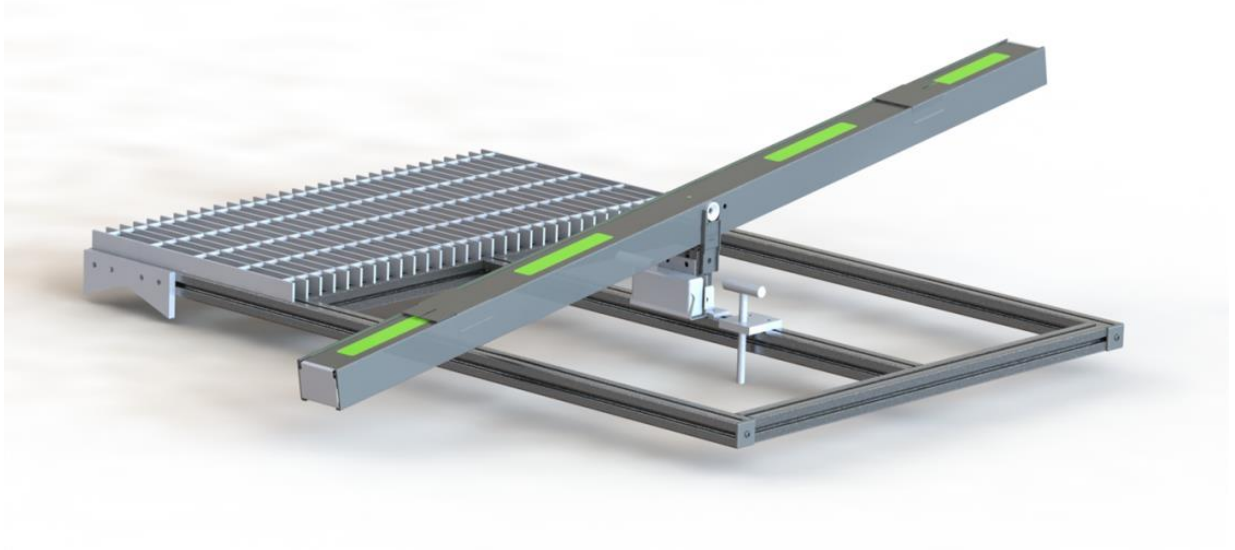

Figure 3: Accuband Calibrator and Calibrator Carrier

4.1.3 WATER COOLED LED BACKLIGHT

A backlight is supplied only with ACCUBAND C965-B model. It is constructed of heavy gage stainless steel with a window in the top of the box and it contains high output LEDs for illuminating the strip edges above. The water manifold provided allows for water to flow over the window to keep it clean and cool.

Refer to DS.ACB.852.1 more information about the water cooled LED backlight.



Figure 4: Accuband Water Cooled LED Backlight

4.1.4 DISCRETE I/O

A discrete I/O system is used for status and measurement signals between the scanner and Level 1 PLC. Discrete I/O systems for a width gage usually consist of two analog inputs, four analog outputs, two digital inputs and five digital outputs. Analog signals typically use voltage ranges of ± 10 V, while current ranges of 4 – 20 mA are also available. It is recommended that the discrete I/O be located in a floor or wall mounted cabinet, but can be installed inside the scanner power supply if required.

4.1.5 OPERATOR'S STATION

The operator's station consists of a PC, monitor, mouse and keyboard. The PC can be supplied with configuration, diagnostic and monitoring software, including the KELK Instrumentation Panel (KIP) and optional data logger. All software is configured beforehand and can be customized on site to meet the user's requirements.

4.1.6 DATA LOGGER

The ibaPDA data logger is accompanied with one license key and allows for 256 signals (analog and digital channels) to be recorded and stored. The signals must be configured in both the scanner and data logger software, and can be customized for user requirements. Additional software packages and license keys can be accommodated if more than 256 signals are required for logging.

4.1.7 COMMUNICATION PROTOCOL

The following level 2 communication protocols are available: Ethernet TCP/IP, EGD or Modbus TCP. Typical communication protocols include setup, real time process information, real time measurements and time synchronization messages.

5 SCOPE OF SUPPLY

5.1 STANDARD EQUIPMENT

- Scanner Assembly, consisting of,
 - 1 x Scanner Head Assembly
 - 1 x Scanner Cable Hose Assembly, 15 m (49 ft.) long
 - 1 x Scanner Support System with Plenum Chamber
 - 1 x Scanner Air Nozzle
 - 1 x Scanner Power Supply
- KELK standard communication protocol for host computer interface

5.2 TYPICAL EQUIPMENT

- Calibrator & Calibrator Carrier, consisting of,
 - 1 x Calibrator, as defined in section 4.1.2
 - 1 x Calibrator Carrier, as defined in section 4.1.2
- LED Backlight, required for C965-B only, as defined in DS.ACB.852.1

5.3 DOCUMENTATION

User manuals, installation drawing packages, installation checklist and commissioning documents are provided in electronic format. English language is standard; other languages may be available (consult KELK).

5.4 SCANNER ASSEMBLY

5.4.1 SCANNER ORDER CODE

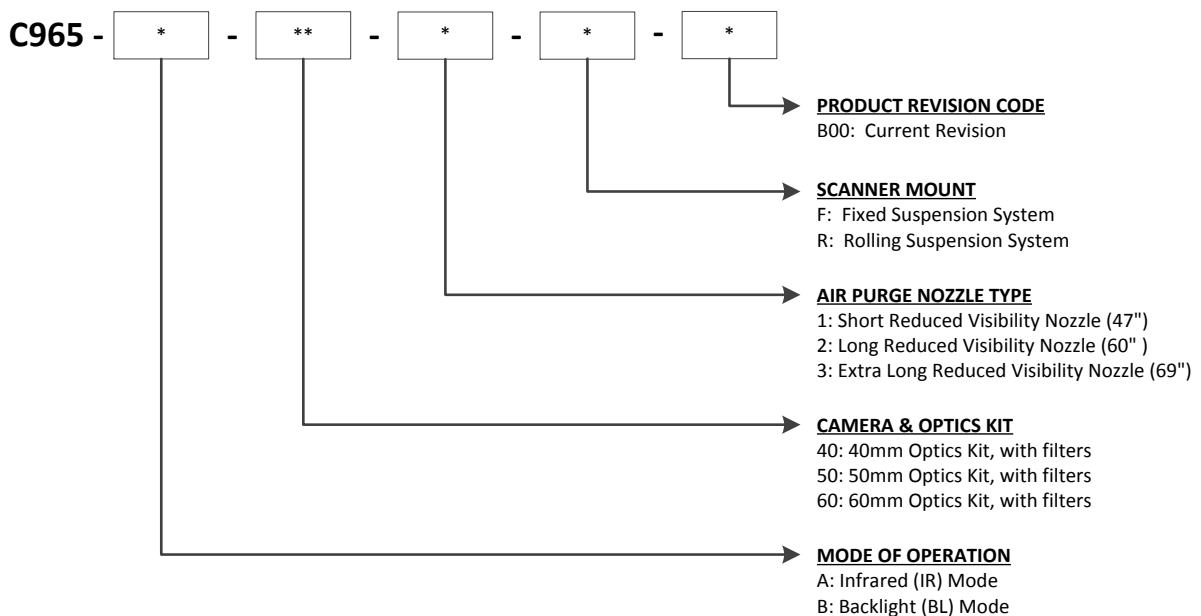

5.4.2 COMMON SCANNER ORDER CODES

| <u>Order Code</u> | <u>Product Description</u> |
|-------------------|--|
| C965-A-40-3-F-B00 | Accuband Scanner, IR Mode, 40 mm Optics Kit and Filters and , with Extra Long Reduced Visibility Nozzle and Fixed Vibration & Suspension System |
| C965-A-50-2-F-B00 | Accuband Scanner, IR Mode, 50 mm Optics Kit and Filters and , with Long Reduced Visibility Nozzle and Fixed Vibration & Suspension System |
| C965-A-60-1-W-B00 | Accuband Scanner, IR Mode, 60 mm Optics Kit and Filters and , with Short Non-Reduced Visibility Nozzle and Wheeled Vibration & Suspension System |

5.4.3 CALIBRATOR ORDER CODE

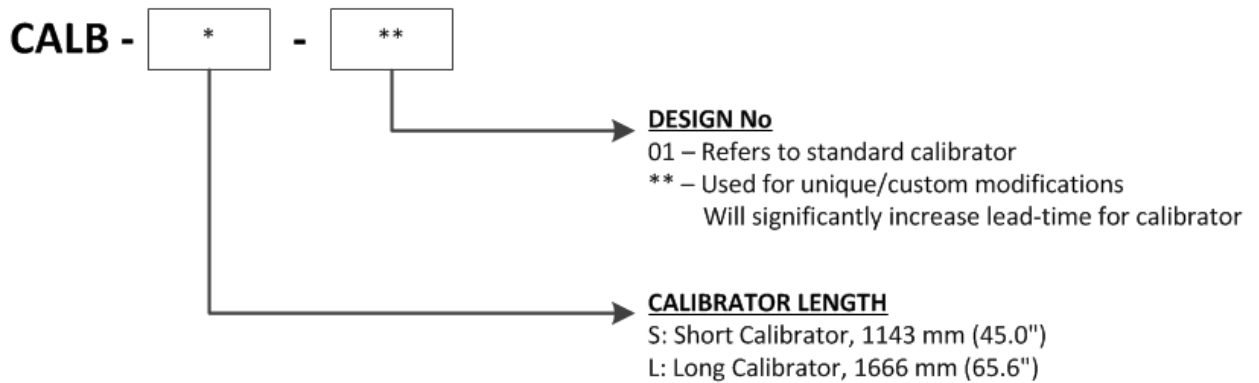

5.4.4 CALIBRATOR CARRIER ORDER CODE

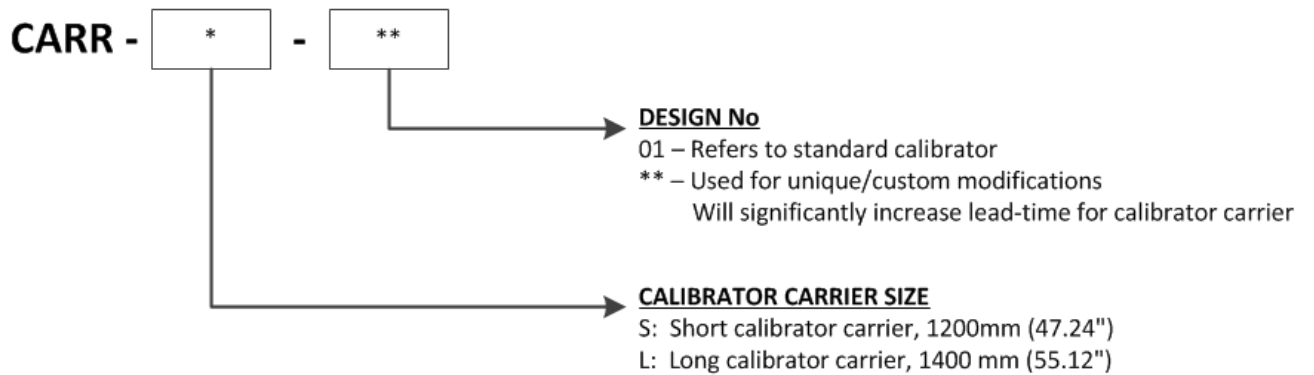

5.4.5 COMMON CALIBRATOR AND CARRIER ORDER CODES

| <u>Order Code</u> | <u>Product Description</u> |
|-------------------|---|
| CALB-S-01 | Short Calibrator, 1193 mm (47.0 in) |
| CALB-L-01 | Long Calibrator, 1666 mm (65.6 in) |
| CARR-S-01 | Short Accuband Calibrator Carrier, 1200 mm (47.2in) |
| CARR-L-01 | Long Accuband Calibrator Carrier, 1400 mm (55.1 in) |

5.5 OPTIONAL EQUIPMENT AND ACCESSORIES

Contact KELK to discuss additional equipment and accessories that may be required, such as:

- Discrete I/O kit for analog and digital I/O
- ibaPDA Data Logger
- Floor or Wall Mounted Cabinet
- Industrial Operator's Station
- Fiber Optic Media Convertors, required for communication connections longer than 100 m (328 ft)

5.6 COMMON SPARES

| <u>Part number</u> | <u>Description</u> |
|--------------------|--|
| PL059063 | SCANNER CAMERA ASSEMBLY |
| PL056193-IR/BL | 40 mm OPTICS KIT (Infrared/ Backlight) |
| PL056194-IR/BL | 50 mm OPTICS KIT (Infrared/ Backlight) |
| PL056195-IR/BL | 60 mm OPTICS KIT (Infrared/ Backlight) |
| PL056196-IR/BL | 80 mm OPTICS KIT (Infrared/ Backlight) |
| PL058844 | CPU ASSEMBLY |
| *08807 | SCANNER POWER SUPPLY, 24 VDC |
| 064200 | SCANNER INTERCONNECT BOARD |
| PL056813-15M | HIGH TEMPERATURE CABLE/HOSE ASSEMBLY, 15 m (49 ft) |
| 064190-1 | CALIBRATOR ILLUMINATOR BOARD FOR SHORT CALIBRATOR |
| 064190-2 | CALIBRATOR ILLUMINATOR BOARD FOR LONG CALIBRATOR |
| 017532-1 | CALIBRATOR MASK, SHORT |
| 017616-1 | CALIBRATOR MASK, LONG |
| *08757 | CALIBRATOR POWER SUPPLY |
| 058874-1 | CALIBRATOR CARRIER PIVOT FORK |
| PL052850 | FIBER OPTIC MEDIA CONVERTER KIT, SC Connector ¹ |

¹ Two kits required for a complete system.

6 SPECIFICATIONS

| | | | | | |
|--------------------------------------|--|---|----------------------------------|----------------------------------|------------------|
| Measurement Range² | Installation Height³ | 3000 mm - 6000 mm (118 in – 236 in) | | | |
| | Material Width | 560 mm - 2200 mm (22 in – 87 in) | | | |
| | Material Edge Temperature | C965-A (IR): 600 °C - 1300 °C (1112 °F - 2372 °F) C965-B (Backlit): below 600 °C (1112 °F) | | | |
| | Vertical Strip Movement | Maximum 450 mm (17.7 in) | | | |
| | Lateral Strip Movement | Up to 0.5 meters (1.7 feet) per second, must remain within field of view | | | |
| Performance | Accuracy | ± 0.2 mm (0.008 in) at 2 sigma, for field of view up to 1250 mm (49 in) or ± 0.4 mm (0.016 in) at 2 sigma, for field of view up to 2200 mm (87 in) | | | |
| | Measurement Frequency | 1000 measurements per second | | | |
| | Head End Response Time | Less than 4 ms | | | |
| Communication | Mill Computer Interface | Physical layer: Cat5e, Fiber Optic Link layer: Ethernet Network layer: MODBUS/TCP | | | |
| Dimensions & Weight | Equipment Size | Scanner Head | Scanner Power Supply | Calibrator (Short / Long) | |
| | | Refer to section 7 | Refer to section 7 | Refer to section 8 | |
| | Equipment Weight | 206 kg / 454 lbs | 23 kg / 51 lbs | 3.3 kg / 7.3 lbs | 4.5 kgs / 10 lbs |
| | Input Power | 24 V DC (From Power Supply) | 100 – 240 V~ 120 VA, 50/60 Hz | 100 – 240 V~ 60 VA, 50/60 Hz | |
| Operating Environment | NEMA Rating | 4 | 4 | N/A | |
| | IP Rating | 65 | 65 | N/A | |
| | Max Ambient Temperature | 70 °C 158 °F | 70 °C 158 °F | 50 °C 122 °F | |
| | Max Humidity | 90 %, non-condensing | | | |
| Safety Hazards | Alignment Laser⁴ | CDRH Class 3a, 10 mW, 635 nm Solid State Laser Cross Hair Generator | | | |

² These values represent typical measurement ranges. For installations that fall outside of these ranges please consult Kelk.

³ Installation height measured from optical plane to pass line.

⁴ **Caution:** Risk of exposure to laser beam. Do not look directly into the laser. Due to its low power, accidental exposure is unlikely to cause injury to skin or eye tissue. Failure to comply with this warning may result in eye damage. MAXIMUM POWER OUTPUT = 10 mW

7 WHAT USERS MUST PROVIDE

| | | |
|------------------------|---|---|
| Installation | Mechanical | <ul style="list-style-type: none"> • Mounting structure with access for maintenance • Air inlet chamber installed below scanner support system and above air nozzle • An unobstructed clear view from Scanner to material surface⁵ • Apron plate and side guide cut outs to prevent reflections • Area under the roll table free of reflecting surfaces (model C965-A), or with sufficient space for a backlight (model C965-B) |
| | Electrical | <ul style="list-style-type: none"> • Power to the Scanner Power Supply and Calibrator (all models) • Power to the Backlight (model C965-B) • Interconnecting power and signal cables not specified in scope of supply |
| System Services | Air (at 20 °C / 68 °F) | <ul style="list-style-type: none"> • Scanner: 1930 L/min at 10.34 KPa to 3068 L/min at 310 KPa (68 CFM at 1.5 PSI to 108 CFM at 45 PSI). Air filtered at 1.1 mm (0.45") • Backlight: Dry Air or Nitrogen, 0.14 BAR (2 PSI), no flow, pressurization only |
| | Cooling (at 5-40 °C / 41-104 °F) | <ul style="list-style-type: none"> • Scanner: water or glycol, 10 L/min (2.6 USGPM) • Backlight: 76 - 189 l/min (20 - 50 USGPM) depending on length of backlight |
| Measurements | Cold Width Compensation | <ul style="list-style-type: none"> • Expansion factors for Cold Width Compensation (if used) • Temperature output for Cold Width Compensation |

⁵ Installations with severe steam or dirt conditions may require additional fans in order to obtain clear field of view from the Scanner down to the detection area.

8 DIMENSIONS

8.1 SCANNER

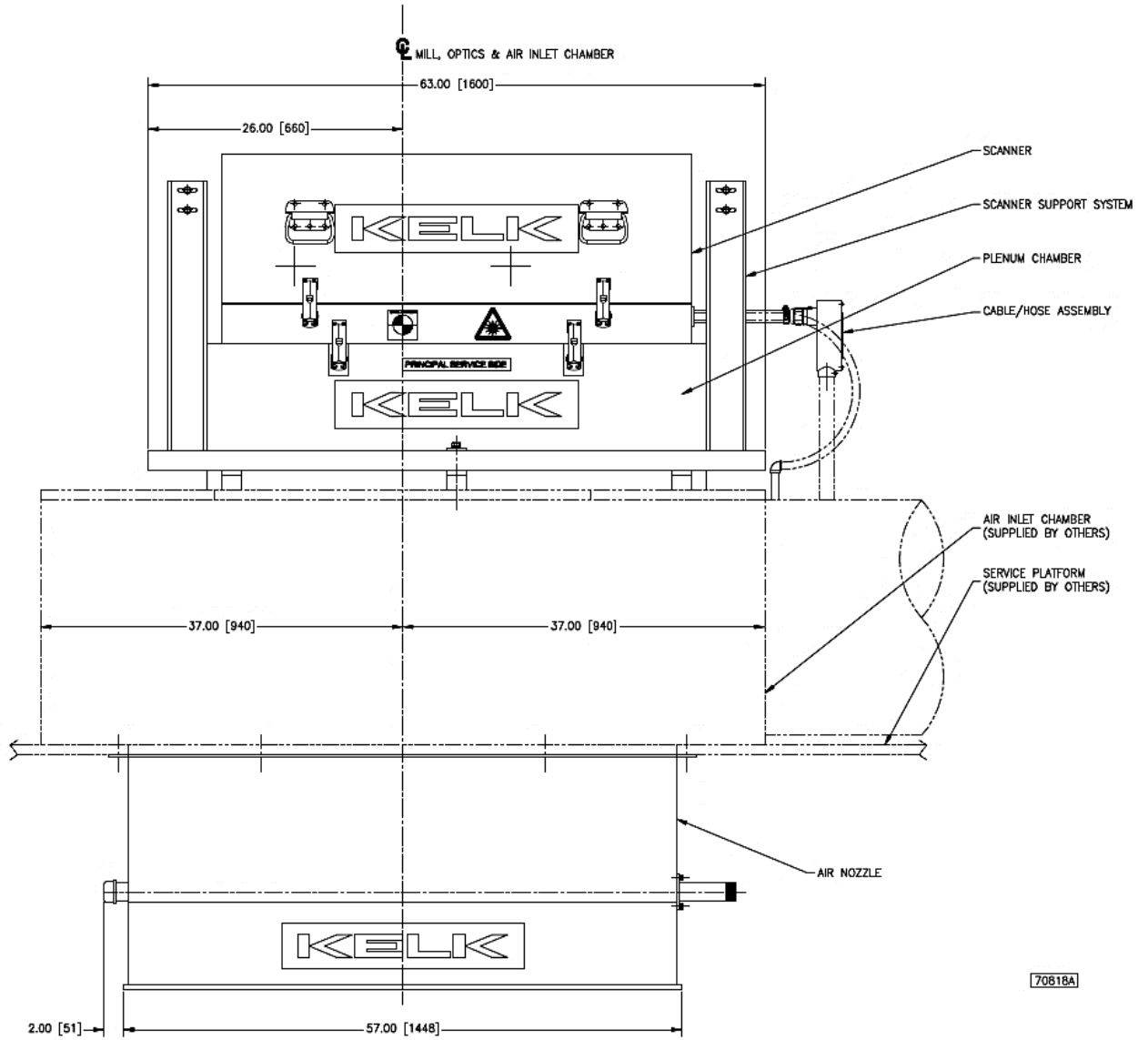

Figure 5: Front view (service side) of Accuband C965 Width Gage

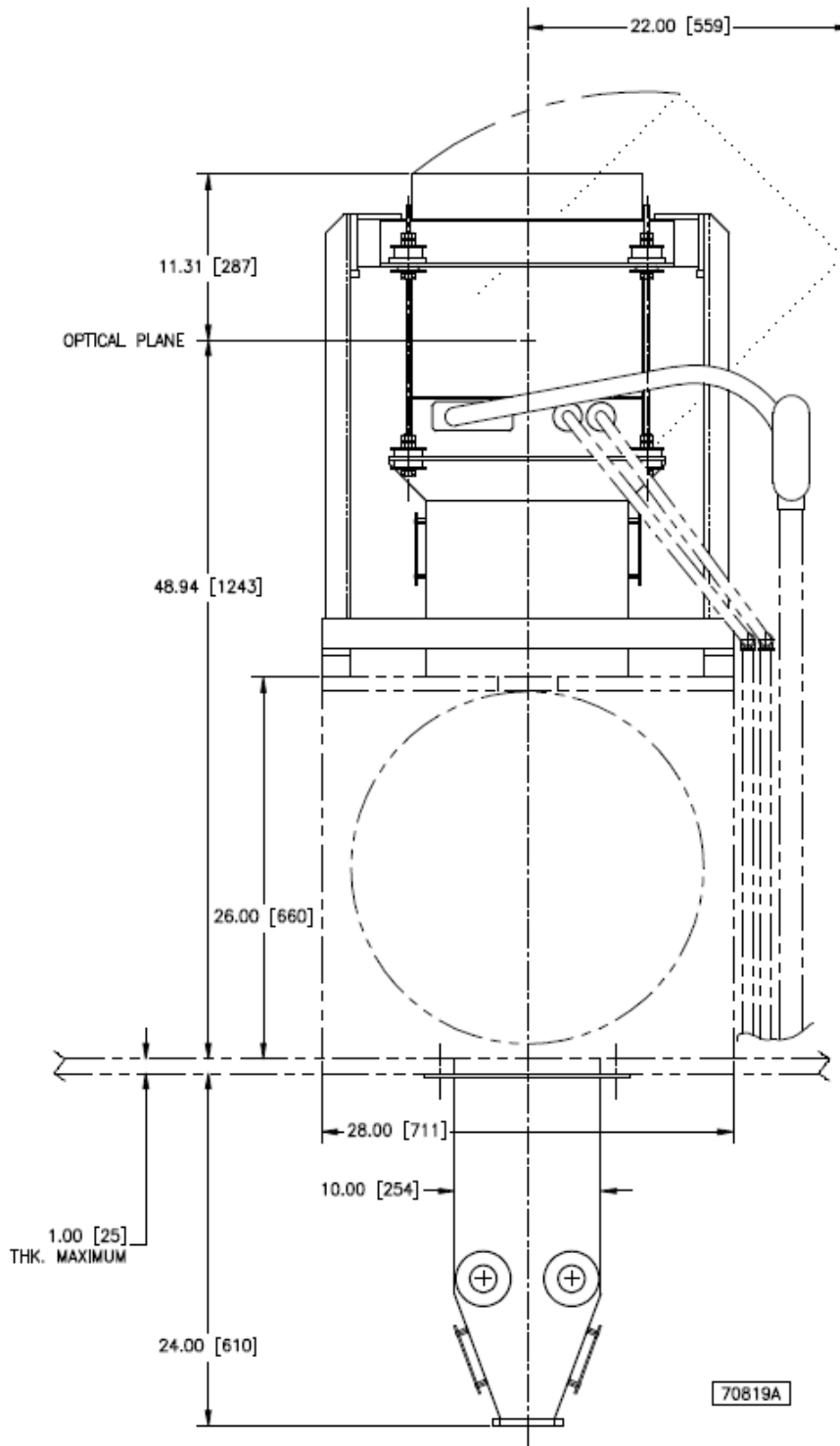

Figure 6: Side view of Accuband C965 Width Gage.

Installation height is measured from optical plane down to passline. Optical plane will vary by ± 15 mm depending on lens size (50 mm lens shown).

8.2 SCANNER POWER SUPPLY

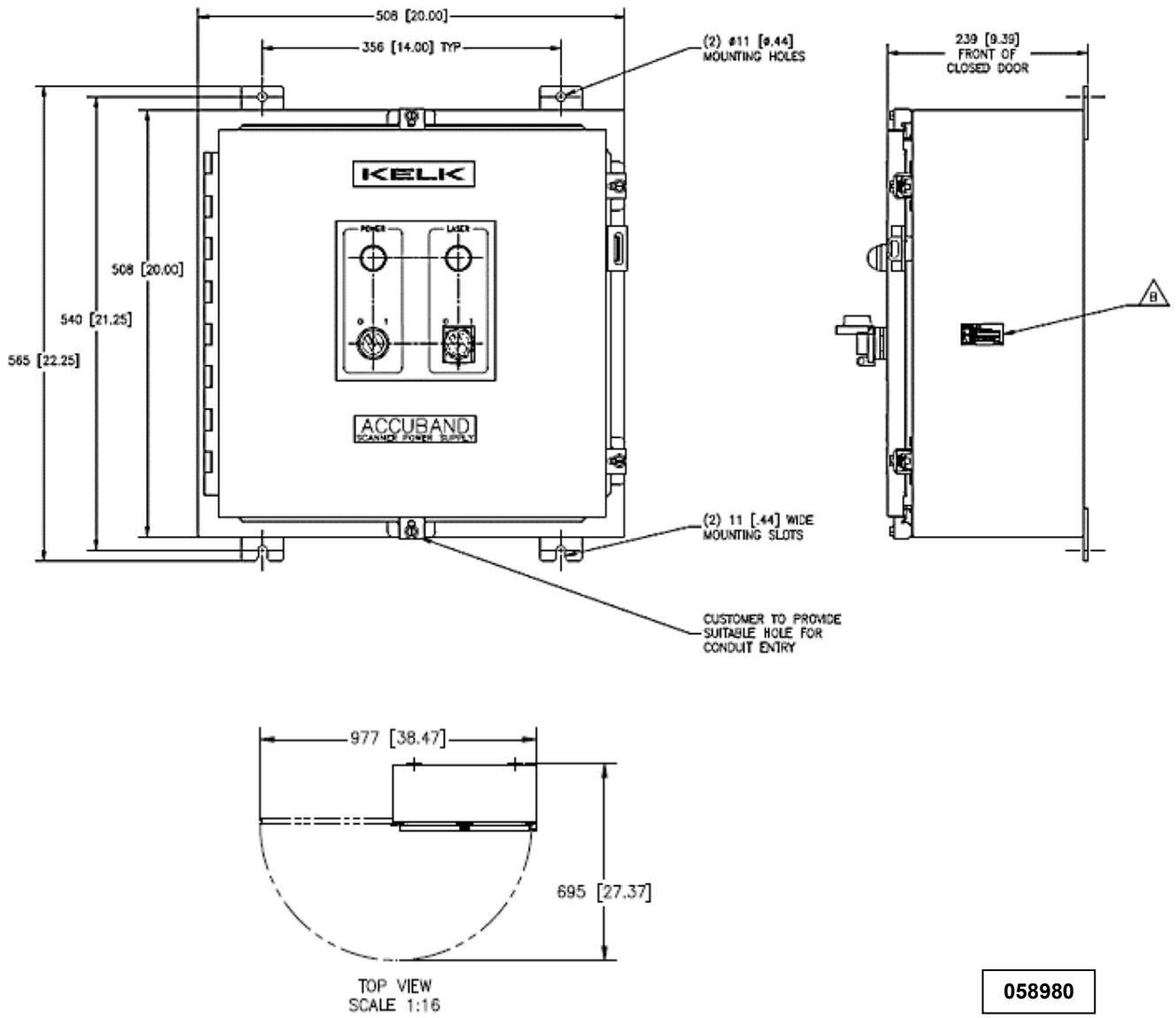
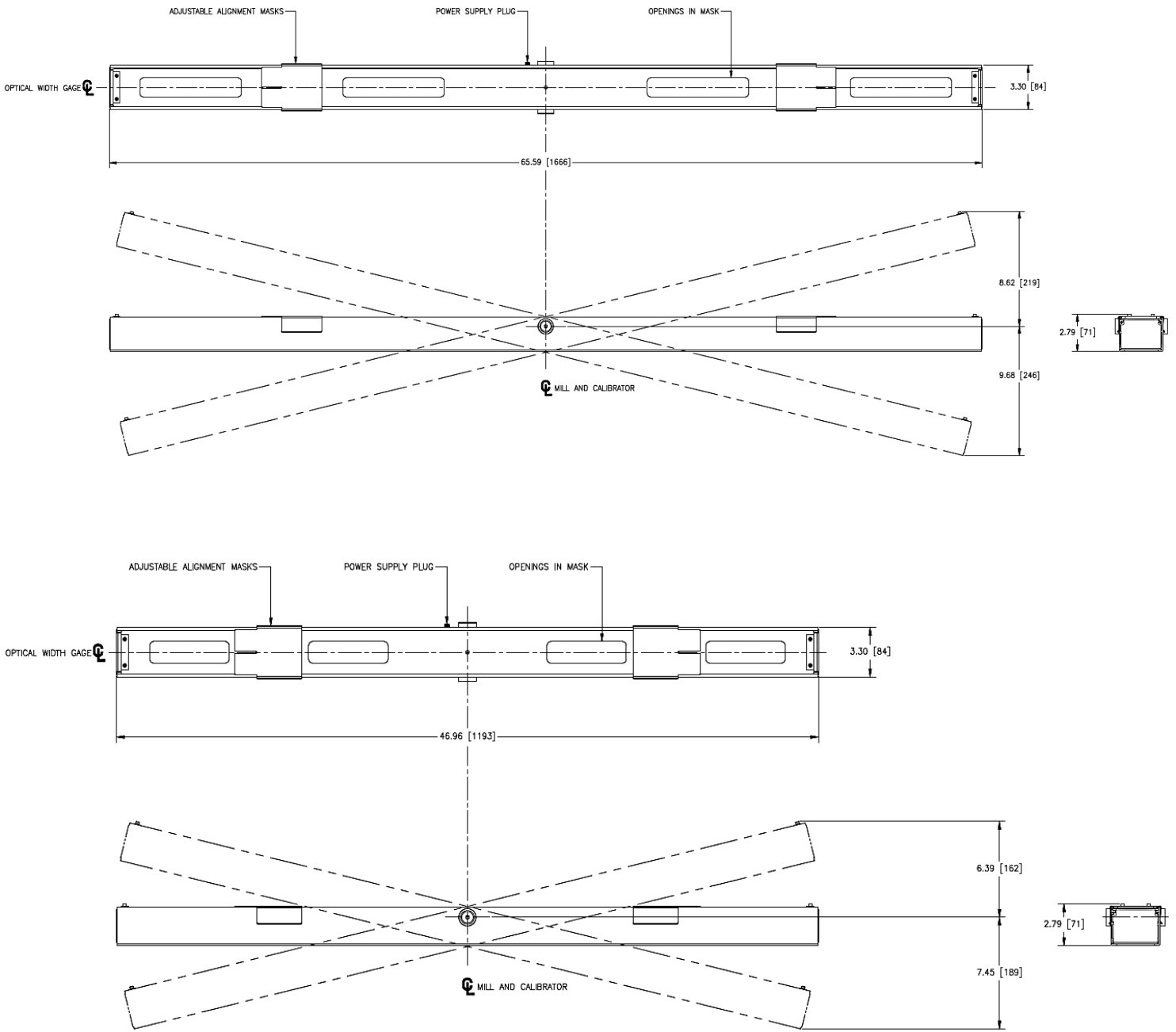

Figure 7: Front, Side and Top view of Scanner Power Supply

8.3 CALIBRATOR



056439

Figure 8: Top, Front and Side view of Long and Short Calibrator

8.4 CALIBRATOR CARRIER

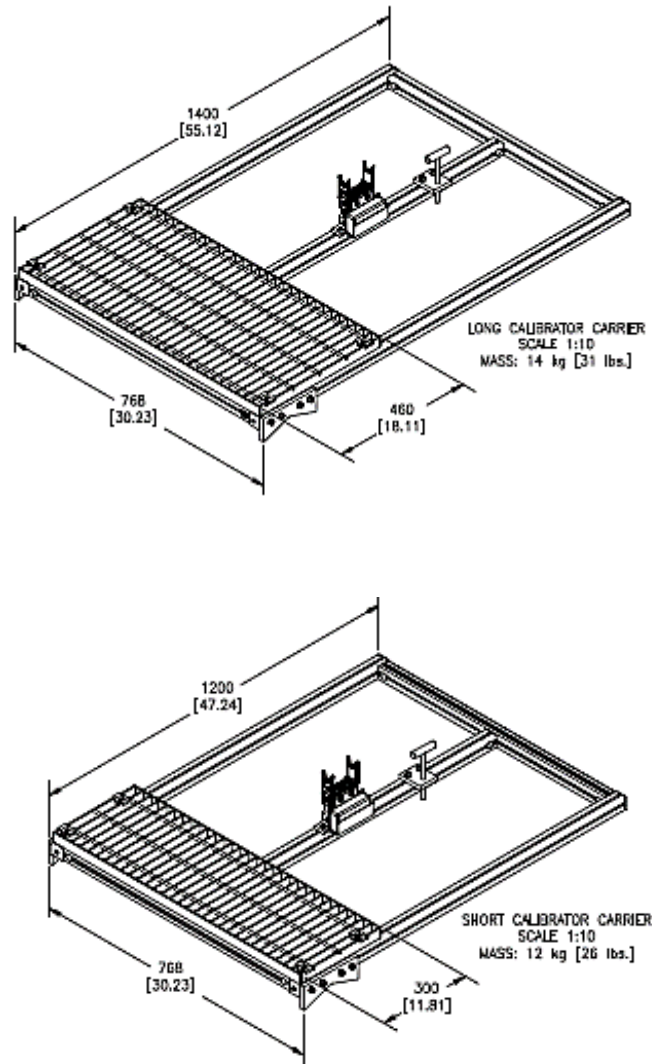

051964

Figure 9: Top, Front and Side view of Long and Short Calibrator Carriers

*Dimensions shown in mm [inch].



Vishay Precision Group Canada ULC (KELK) | 48 Lesmill Road, Toronto, Ontario, M3B 2T5, Canada
 T: +1 416 445 5850 | F: +1 416 445 5972 | www.kelk.com | kelk@vpgsensors.com

Information subject to change without notice
 Printed in Canada