

Technical data



- Measuring range in Nm (+/-): 2,5; 5; 7,5; 17,5; 75; 175; 250; 500
- Rotational speed: ≤ 5.000 rpm
- Accuracy: ≤ ±1 %
- Temperature range: -40 °C to +85 °C
- Protection class: IP50
- Output signals: 0-5 V
- Output frequency: 1.000 Hz



Your advantages

- Made in Germany (Munich, Bavaria)
- Delivery ex warehouse (< two weeks)
- Best price-performance ratio
- Integrated electronic (Plug & Play)
- Contactless measurement system
- Including 5 m cable and calibration certificate

Short description

The series 2000 is the most easy and affordable entry into torque measurement technology.

This series is mainly used in testing facilities, automation process, production lines e. g. end-of-line tests and Research and Development.

Transmitted torque can be measured statically and dynamically in real time. Shaft is available as Round shaft and Square shaft. Series 2000 offers a 0-5 V output signal.

The sensor is provided as a complete unit with integrated evaluation electronic, including 5 m cable, keystones (Round shaft) and calibration certificate.

Optionally, the 2000 Series is available for explosive atmospheres



- Conform to the EU ATEX directives for Zone 2
- Additional zones on request

Model series 2000

Model series 2200 round shaft	Unit	Nominal torque bidirectional (+/-)	Load bidirectional (+/-) in % ¹			Rotational speed [rpm]
			100 - 130	130 - 200	> 200	
Ø 9 mm	[Nm]	2,5	In specification	Set up opposite directional torque or recalibration by NCTE	To recalibration by NCTE	5.000*
		5				
		7,5				
		17,5				
Ø 14 mm		75				
Ø 19 mm		175				
Ø 25 mm	250					
		500				

Model series 2100 square shaft	Unit	Nominal torque bidirectional (+/-)	Load bidirectional (+/-) in %			Rotational speed [rpm]
			100 - 130	130 - 200	> 200	
¼ inch	[Nm]	2,5	In specification	Set up opposite directional torque or recalibration by NCTE	To recalibration by NCTE	5.000*
		5				
		7,5				
		17,5				
⅜ inch		75				
½ inch		175				
¾ inch	250					
		500				

In case of an overload situation of the nominal torque it is possible to get the sensor back in specification. To do so please set up the same overload situation in the opposite direction. This means in case of an overload situation by 150 % positive load you can get the sensor back in specification by setting up a negative overload of 150 %.

NCTE is able to recalibrate any sensor until ultimate torque.

¹ By using feather keys the overload reduces to 170%.

* Higher speed possible in clearance-free adaption.

Load characteristics

Model series 2000 measuring range	Unit	Axial force [N] ²	Lateral limit force [N]	Bending limit moment [Nm]
2,5 und 5	[Nm]	1.000	20	2,5
7,5		1.000	30	3,7
17,5		1.000	100	12,5
75		2.600	300	41,7
175 und 250		4.000	500	89,5
500		7.000	800	176

Each type of irregular stress can only be permitted with its given limit value (bending moment, lateral force or axial force, exceeding the nominal torque) if none of the others can occur. Otherwise the permitted limits must be reduced. If for instance 30 % of the limited bending moment and also 30 % of the limited lateral force are present, only 40 % of the limited axial force are permitted, provided that the nominal torque is not exceeded.

Technical characteristics

No.	Model	Unit	Series 2000
	Accuracy class ³		1,0
		Unit	Value
1	Linearity deviation incl. hysteresis	%ME ⁴	≤ ±1,0
2	Rotational Signal Uniformity (RSU)		≤ ±1,0
3	Repeatability		≤ ±0,05
Output signal in general		Unit	Value
4	Frequency range, -3dB point, Bessel characteristics	Hz	1.000
5	Analog signal	V	0 ... 5
6	Signal at torque = Zero ⁵	V	2,5
7	Signal at positive nominal torque ⁵	V	4,5
8	Signal at negative nominal torque ⁵	V	0,5
9	Calibration parameter (normed) ⁵	V/Nm	Identification label
10	Output resistance	Ω	50

² Direct acting axial force on the shaft. If the force affects the snap ring, just 50 % of the force is permitted.

³ The accuracy class implies that taken separately both the linearity deviation as well as the rotational signal uniformity are either lower than or equal to the value of the accuracy class.

⁴ %ME: related to a full scale measurement range.

⁵ Please check the exact data at the sensors calibration certificate.

Effect of temperature		Unit	Value							
12	Zero point drift over temperature	%/10 K	≤ 0,5							
13	Signal drift over temperature within nominal temperature range	%/10 K	≤ 0,5							
Power supply		Unit	Value							
14	Supply voltage	VDC	6 ... 15							
15	Current consumption (max.)	mA	10							
16	Start-up peak	mA	≤ 40							
17	Absolute max. supply voltage	VDC	18							
General information		Unit	Value							
18	Protection class according to EN 60529 ⁶	IP	50							
19	Reference temperature	°C	+15 ... +35							
20	Operational temperature range	°C	-40 ... +85							
21	Storage temperature range	°C	-40 ... +85							
22	Bearing operating hours	h	approx. 20.000							
Nominal rated torque M (bi-directional)		Nm	2,5	5	7,5	17,5	75	175	250	500
23	Weight	Rd	g	386	392	400	685	856	1.230	
		Sq		395	401	414	652	754	878	
24	Moment of inertia	Rd	g mm ²	597	662	1.073	4.922	19.126	79.754	
		Sq		582	648	904	3.339	13.294	57.770	

⁶ Wiring connected.

Dimensions

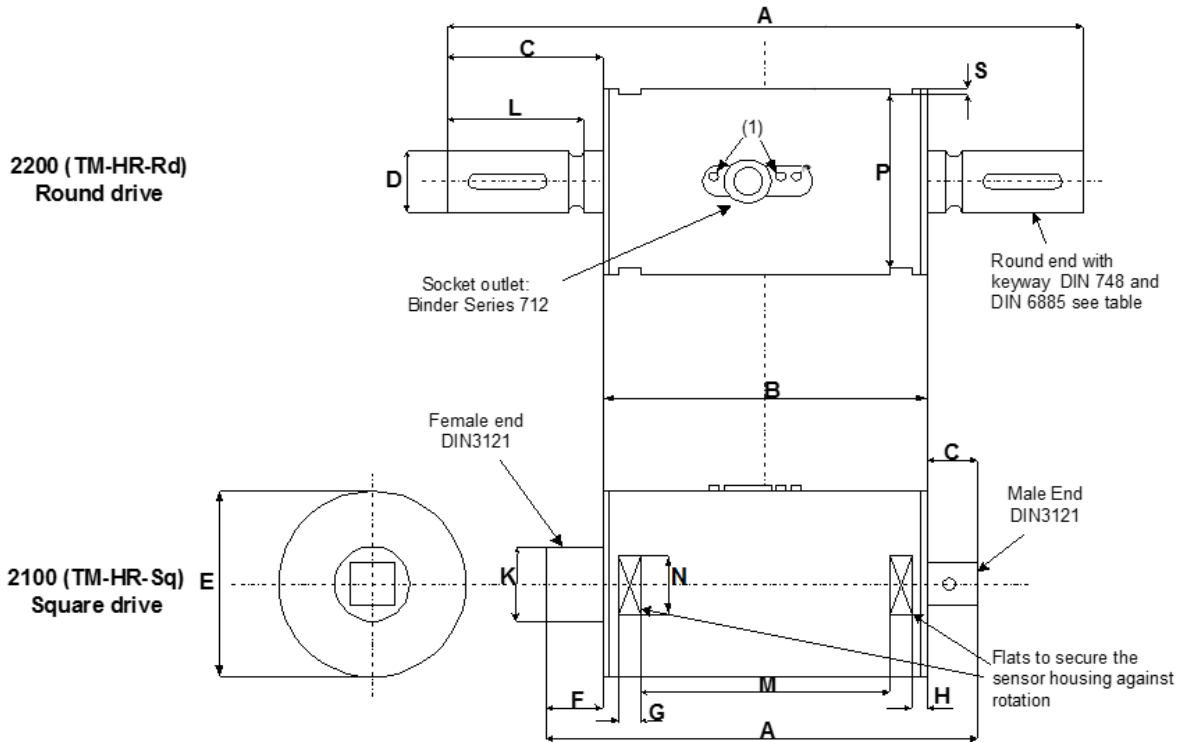

Do not loosen or tighten the mounting nuts of the socket and the lock screws

Dimensions	Round shaft nominal torque [Nm]				Square shaft nominal torque [Nm]			
	∅ 9 mm	∅ 14 mm	∅ 19 mm	∅ 25 mm	1/4 inch	3/8 inch	1/2 inch	3/4 inch
Nominal torque [Nm]	2,5 - 5 - 7,5 - 17,5	75	175 - 250	500	2,5 - 5 - 7,5 - 17,5	75	175 - 250	500
A	125	139	179	220	95,5	107	123,5	146
B	70	70	70	87	70	70	70	87
C	27,5	34,5	54,5	66,6	9,5	13	18,5	29,6
D	9k6	14k6	19k6	25k6	-	-	-	-
E	40	50	50	60	40	50	50	60
F	-	-	-	-	16	24	35	29,6
G	8	8	8	10,5	8	8	8	10,5
H	5	5	5	2	5	5	5	2
K	-	-	-	-	12	18	24	33,5
L	23	30	50	≅ C	-	-	-	-
M	43,9	43,9	43,9	61,4	43,9	43,9	43,9	61,4
N	15	18	18	19	15	18	18	19
P	37	47	47	57	37	47	47	57
S	1,5	1,5	1,5	1,5	1,5	1,5	1,5	1,5

Dimensions keyway [mm]				Keystones		
Round shaft	Width	Depth	Length	Height	Length	Amount
∅ 9 mm	3	1,8	18,5	3	18	1
∅ 14 mm	5	3	25,5	5	25	1
∅ 19 mm	6	3,5	45,5	6	45	1
∅ 25 mm	8	4	50,5	7	50	2

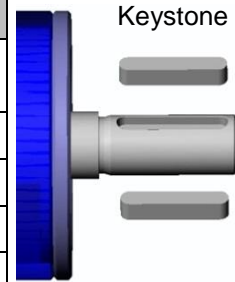

Connection plan

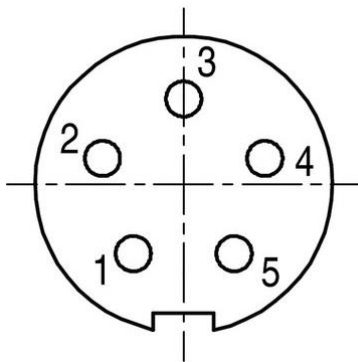

Connector
Power supply and outputs

Type	Binder series s712-M9 connector IP67 colour coding according to DIN 47100		
Pin	Colour	Pin	Value
1	White	Supply Voltage V_{CC}	6 V – 15 V
2	Brown	Signal Output analogue	-
3	Black	Ground GND	-
4	Blue	Not used	-
5	Grey	Reference Voltage V_{ref}	2,5 V

The output V_{ref} is a constant 2.5 V and represents the virtual zero point for direct +/- torque measurement.

Connection example:

Connection for measurement between 0,5 ... 4,5 V
e.g. 2.5 V equals to approx. 0 Nm.

Grey and blue wires are not in use.

Connection for measurement between - 2,0 ... + 2,0 V
e.g. 0 V equals to approx. 0 Nm.

Blue wire is not in use.

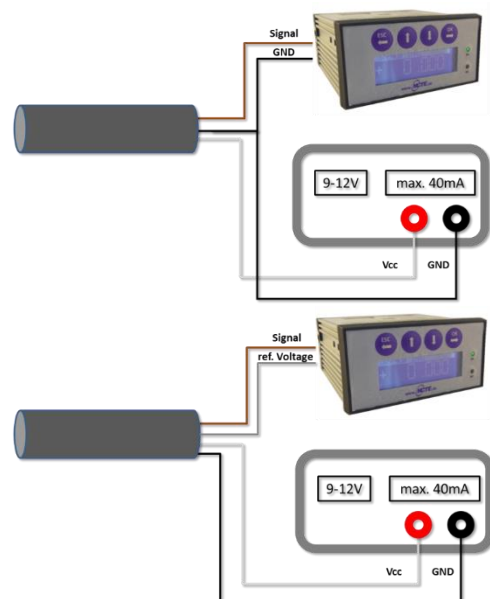

Order options

Series 2000 accuracy 1 %		Price
Series 2100 square shaft		
Series 2200 round shaft		
Measurement range		
2,5	Nm including 5 m cable and calibration certificate	
5	Nm including 5 m cable and calibration certificate	
7,5	Nm including 5 m cable and calibration certificate	
17,5	Nm including 5 m cable and calibration certificate	
75	Nm including 5 m cable and calibration certificate	
175	Nm including 5 m cable and calibration certificate	
250	Nm including 5 m cable and calibration certificate	
500	Nm including 5 m cable and calibration certificate	

Please feel free to contact your LUCHSINGER sales team for additional information. E

Email: info@luchsinger.it or Phone: +39 035 462678

By **Series 2000** please keep in mind to order it with sensor bracket (at accessories) as the housing has no treats.

Series 2000 - Accessories		Price
Sensor bracket		
1	2,5 – 17,5 Nm (order number: 400006-ATS100)	
2	75 – 250 Nm (order number: 400006-ATS101)	
NCTE Readout Unit works with all NCTE Sensors		
A	Torque sensor input: Voltage output 0-5 V and 0-10 V Order number: 400010-ATS001 1 angle encoder input, A/B USB interface, Windows software included SD card slot	
X	Customized couplings (only for round shaft), price on request	

NCTE Readout Unit is also available for a current output 4-20 mA torque sensor input.

Instruction manual

The series 2000 is the most easy and affordable entry into torque measurement technology.

This series is mainly used in testing facilities, automation process, production lines e. g. end-of-line tests and Research and Development.

Transmitted torque can be measured statically and dynamically in real time. Shaft is available as Round shaft and Square shaft. Series 2000 offers a 0-5 V output signal.

The sensor is provided as a complete unit with integrated evaluation electronic.

General

Please read the instructions carefully before using it for the first time and only use the product for the intended purpose. Keep this manual for future reference to avoid any incorrect use. The instruction manual can also be downloaded as a PDF file under the following link: <http://www.ncte.com/service/downloads/>, or can be requested from our customer service at: info@luchsinger.it.

Local representative

The local representative of the torque sensor series 2000 is:

LUCHSINGER SRL

Via Bergamo, 25

24035 Curno (BG) Germany

Tel.: +39 035 462678

Fax: +39 035 462790

EU directives and standards

The series 2000 is compliant with the European Union directives and the European Standards listed in this document. Further requirements are to be requested from the manufacturer.

Scope of delivery

The torque sensor set consists of the sensor series 2000 (signal pick-up and signal processing integrated into sensor housing), one **connecting cable** 5 m with a **soldered plug** (binder plug no. 99-0426-10-08), key stones (round shaft) or square sleeve (Square shaft) and the calibration certificate.

Datasheets and instruction manuals are available at www.ncte.com.

Intended Use

Use the product only as described in the instruction manual. Any other use is considered as improper and may result in property damage or even personal injury. The manufacturer assumes no liability for damage caused by improper or incorrect use.

Installation and removal

Make sure to install the sensor shafts exactly with the proper aligned connecting shafts. The key stone adapter/square endings of the connecting shafts are to be attached forceless to the corresponding ones of the sensor. No external axial force should be on the housing of the sensor from distortion. A maximum cable length of 5 m must not be exceeded. Using a cable or connector other than supplied by **NCTE**, or a similar cable that is of a different length may affect the overall performance of the sensor.

Do not remove the shaft with torque applied to the sensor.

Interface description

Mechanical connection:

The key stone adapters on both ends of the measurement shaft are intended for torque transmission.

Electrical connector:

On the sensor housing there is a 8-pin socket for the power supply and the signal output (see chapter connection plan).

Operation (in regular case or in optimal case)

Optimal measurement parameters can be achieved if the sensor is applied in accordance to the specification. By compliance with the specification the sensor works generally trouble-free and maintenance-free.

Irregular operation, measures against disturbance

The mechanical overload on the sensor (e. g. exceeding of maximum allowed torque or severe vibrations) may cause damage to the sensor and in consequence the incorrect signal output. In such cases please do not open the sensor. Contact **LUCHSINGER** directly for assistance.

Commissioning

After sensor installation pay attention to the following:

- The sensor may only be operated with a shielding.
- Switch on the power supply unit and check the supply voltage. Peak voltage must be avoided! Be sure to verify the power supply voltage before connecting the sensor!
- Connect the sensor to the power supply unit by using the delivered cable.
- Connect the sensor output to a high-resistance device such as an A/D converter, oscilloscope, pc measurement board. The sensor should be in mechanical unloaded state while connecting it.

Shaft coating

The shafts are protected on both sides with a film of anticorrosion wax. We recommend to leave the protection permanent. As far as technologically needed, the coating can be removed with spirit / ethanol

Handling and transportation

By handling, storage and transportation keep the sensor away from magnetic or electromagnetic fields which may exceed the maximal intensity defined from EMC (chapter technical characteristics) for instance degaussing machines.

Precautions

- Do not open the sensor housing under any circumstances.
- Do not remove or loosen the locking rings on the shaft ends.
- Do not loosen or tighten the flange-mounting nut of the socket-connector (chapter dimensions).
- Use only a separate power supply for the sensor.
- Use the sensor only according to the specification (chapter technical characteristics).

Maintenance and overhaul

As part of your testing and measuring equipment management, we recommend regular checking of your testing and measuring equipment. Please also observe the corresponding standards and guidelines.

Recommended NCTE maintenance plan

Recalibration	12 month
Control of wiring, plug and shaft	12 month

Repairs

Repairs must be carried out exclusively by employees of NCTE AG. The sensor must be sent to the NCTE AG together with an RMA formula (Return Merchandise Authorization). You will receive an RMA formula via the NCTE service-hotline.

Disposal

Dispose the product and all associated components via an authorized waste disposal company. Please observe the currently applicable regulations. If in doubt, ask your disposal centre for environmentally friendly disposal.

Distributore italiano:



LUCHSINGER_{srl}
sensori e strumenti

Telefono: +39 035 462678

email: info@luchsinger.it

www.luchsinger.it