

Technical data



- Nominal torque in Nm (+/-): 10.000; 15.000
- Customer-specific calibration (> 15.000 Nm) upon request
- Rotational speed: ≤ 2.500 rpm
- Accuracy: $\leq \pm 0,5$ %
- Temperature range: -30 °C to $+85$ °C
- Protection class: IP50; IP65
- Output signals: 0-10 V/4-20 mA
- Output frequency: 2.500 Hz

Your advantages

- Made in Germany (Munich, Bavaria)
- Fast availability
- Best price-performance ratio
- Integrated electronic (Plug & Play)
- Contactless measurement system
- Including 5 m cable and calibration certificate

Short description

The 5000 series is specially designed for applications with very high rated torques

The series 5000 is mainly used in test fields of the automotive industry with the highest demands on torque sensors, in railway applications, in component stress tests or process monitoring in heavy goods / container handling as well as in professional test bed construction and quality assurance.

With the 5000 series, torque can be measured both statically and dynamically in real time.

Series 5000 offers a wide range of output signals such as 0-10 V and 4-20 mA.

The sensor is provided as a complete unit with integrated evaluation electronic, including 5 m cable and calibration certificate.

Model series 5000

Series 5000	Nominal torque bidirectional (+/-)	Max. Load during transfer operation	Max. At threshold load operation	Rotational speed [rpm]
1	Up to 15.000 Nm	+12.000 Nm to - 12.000 Nm	0 up to + 15.000 Nm or 0 up to -15.000 Nm	2.500

The maximum permissible dynamic axial tensile load is 16,000 Nm.

Technical characteristics

No.	Model	Unit	Series 5000	
	Accuracy class ¹		0,5	
		Unit	Value	
1	Linearity deviation incl. hysteresis	%ME ²	< ±0,5	
2	Rotational Signal Uniformity (RSU)		< ±0,5	
3	Repeatability		< ±0,1	
Output signal in general		Unit	Value	
4	Frequency range, -3dB point, Bessel characteristics	Hz	2.500	
5	Analog signal	V mA	0 ... 10	4 ... 20
6	Signal at torque = Zero ³	V mA	5	12
7	Signal at positive nominal torque ³	V mA	9	19
8	Signal at negative nominal torque ³	V mA	1	5
9	Calibration parameter (normed) ³	V/Nm mA/Nm	4 V/Measurement range	8 mA/Measurement range
10	Error output	V mA	10	22
11	Output resistance	Ω	50	
Effect of temperature		Unit	Value	
12	Zero point drift over temperature	%/10 K	< 0,5	
13	Signal drift over temperature within nominal temperature range	%/10 K	< 0,5	
Power supply		Unit	Value	
14	Supply voltage	VDC	9 ... 28	
15	Current consumption (max.)	mA	40	
16	Start-up peak	mA	< 100	
17	Absolute max. supply voltage	VDC	30	
General information		Unit	Value	
18	Protection class according to EN 60529 ⁴	IP	50/65	
19	Reference temperature	°C	+15 ... +35	
20	Operational temperature range	°C	-40 ... +85	
21	Storage temperature range	°C	-40 ... +85	
22	Bearing operating hours	h	approx. 20.000	
23	Weight	kg	approx. 21	

¹ The accuracy class implies that taken separately both the linearity deviation as well as the rotational signal uniformity are either lower than or equal to the value of the accuracy class.

² %ME: related to a full scale measurement range.

³ Please check the exact data at the sensors calibration certificate.

⁴ Wiring connected.

Dimensions

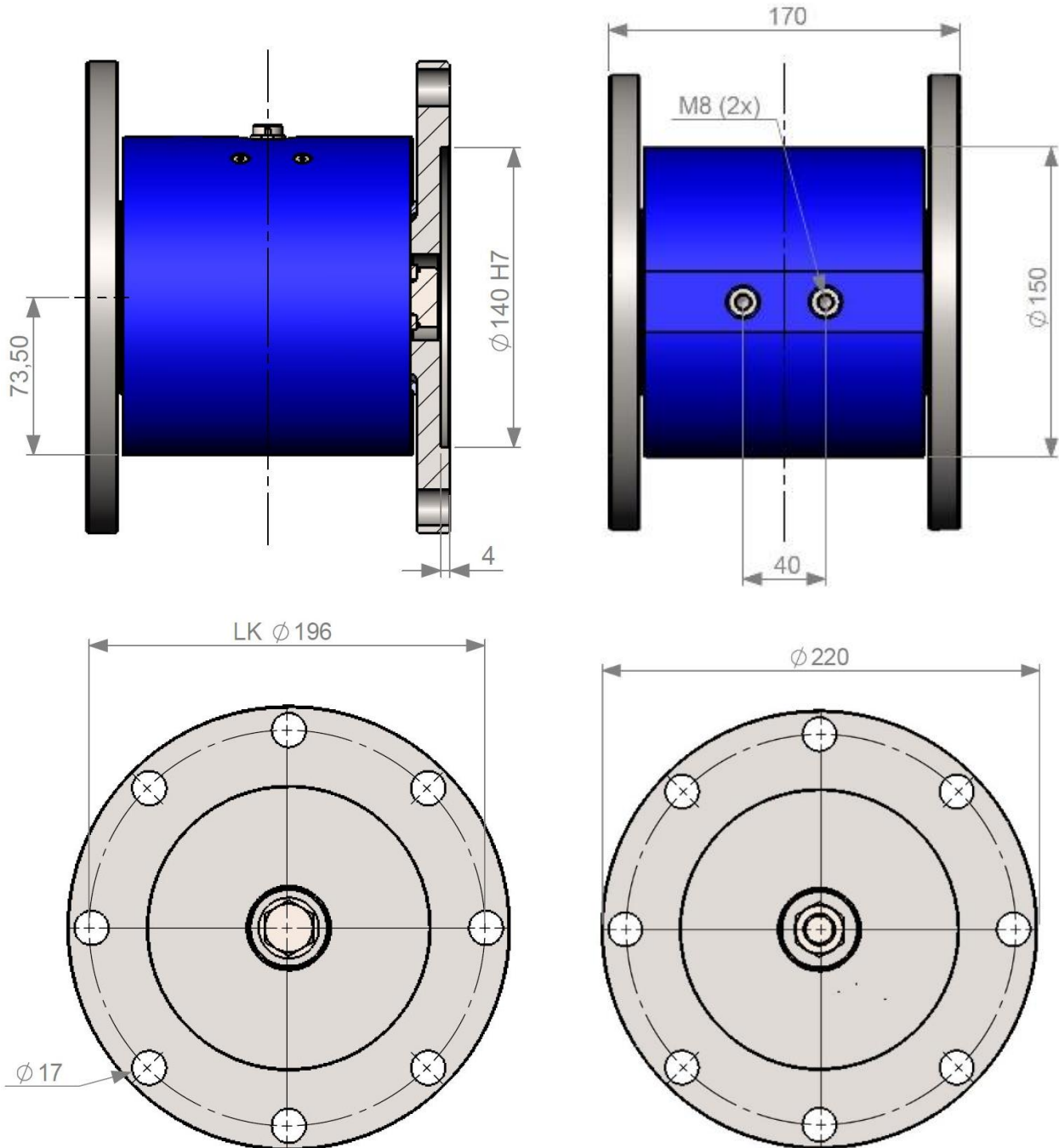

Only M16 screws of strength class 12.9 are to be used.
The tightening torque is 362 Nm

Connection plan

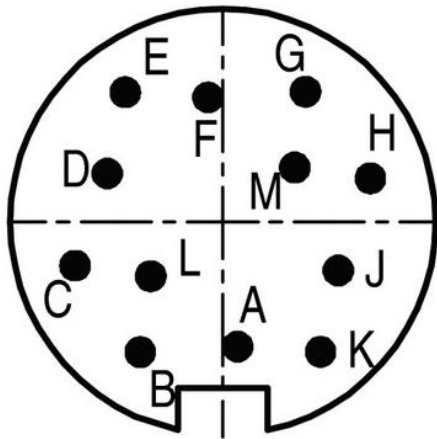

Connector
Power supply and outputs

Type	Binder series 423 connector IP67 colour code according to DIN 47100		
Pin	Colour	Description	Value
A	White	-	-
B	Brown	-	-
C	Green	-	-
D	Yellow	-	-
E	Grey	Analog GND	-
F	Pink	Analog voltage Analog current	0 ... 10 V 4 ... 20 mA
G	Blue	Ground GND	-
H	Red	Supply voltage VCC	9 ... 28 V
J	Black	-	-
K	Violet	-	-
L	Grey-Pink	-	-
M	Red-Blue	-	-

Connection example:

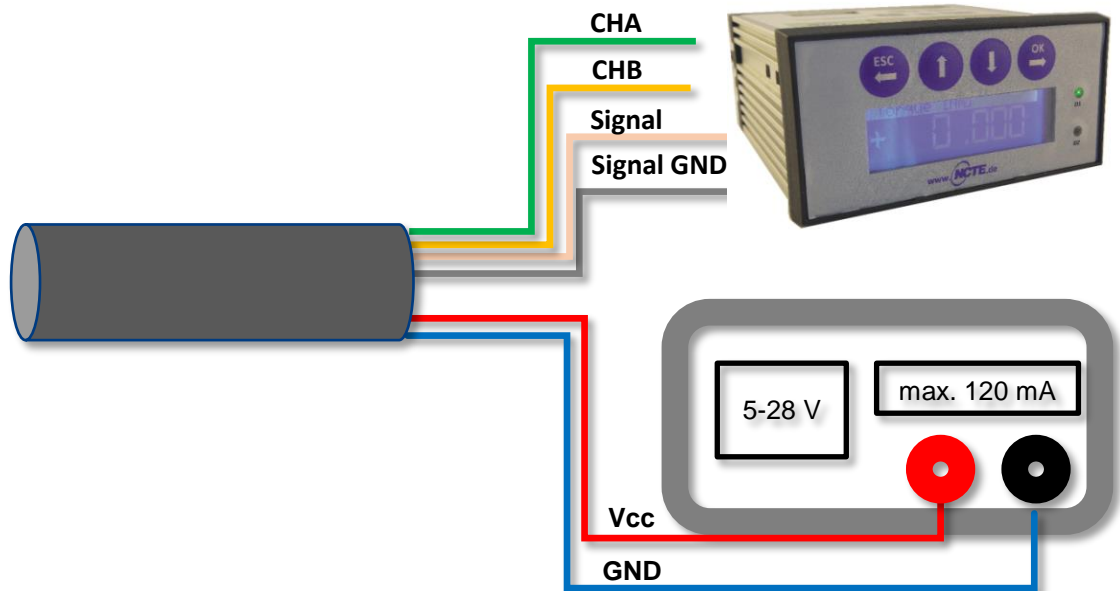

Order options

Series 5000 accuracy 0,5 %				Price
Measurement range				
10	kNm including 5 m cable and calibration certificate			
15	kNm including 5 m cable and calibration certificate			
Angle sensor				
0	Without angle sensor			
Analog output				
A	Voltage output 0-10 V			
S	Current output 4-20 mA			
Protection class according to EN 60529				
0	IP50			
1	IP65			
5000				

Accessories				Price
NCTE Readout works with all NCTE Sensors				
A	Torque sensor input: Voltage output 0-5 V and 0-10 V Order number: 400010-ATS001 1 angle encoder input, A/B USB interface, Windows software included SD card slot			
S	Torque sensor input: current output 4-20 mA Order number: 400010-ATS002 1 angle encoder input, A/B USB interface, Windows software included SD card slot			

Instruction manual

The 5000 series is specially designed for applications with very high rated torques

The series 5000 is mainly used in test fields of the automotive industry with the highest demands on torque sensors, in railway applications, in component stress tests or process monitoring in heavy goods / container handling as well as in professional test bed construction and quality assurance.

With the 5000 series, torque can be measured both statically and dynamically in real time.

Series 5000 offers a wide range of output signals such as 0-10 V and 4-20 mA.

The sensor is provided as a complete unit with integrated evaluation electronic, including 5 m cable and calibration certificate.

General

Please read the instructions carefully before using it for the first time and only use the product for the intended purpose. Keep this manual for future reference to avoid any incorrect use. The instruction manual can also be downloaded as a PDF file under the following link: <http://www.ncte.com/service/downloads/>.

The explanation and operating instructions refer only to the machine in the condition in which it was placed on the market. Subsequent parts attached by the end user and / or subsequent interventions are not taken into consideration.

Manufacturer

The manufacturer of the torque sensor series 5000 is:

NCTE AG

Raiffeisenallee 3

82041 Oberhaching

Germany

Tel.: + 49 (0) 89 665 619-0

Fax: + 49 (0) 89 665 619-29

Name of the machine

Torque sensor

Type: 5000

Serial number: 400013

EU directives and standards

The series 5000 is compliant with the European Union directives and the European Standards listed in this document. Further requirements are to be requested from the manufacturer.

Scope of delivery

The torque sensor system consists of a calibrated sensor with integrated signal acquisition / processing in the housing, a **5 m long connecting cable** with **plug** (binder plug No. 99-5630-15-12) and **calibration certificate**.

Datasheets and instruction manuals are available at www.ncte.com.

Intended Use

Use the product only as described in the instruction manual. Any other use is considered as improper and may result in property damage or even personal injury. The manufacturer assumes no liability for damage caused by improper or incorrect use.

Installation and removal

Make sure to install the sensor shafts exactly with the proper aligned connecting shafts. The key stone adapter/square endings of the connecting shafts are to be attached forceless to the corresponding ones of the sensor. No external axial force should be on the housing of the sensor from distortion. A maximum cable length of 5 m must not to be exceeded. Using a cable or connector other than supplied by **NCTE**, or a similar cable that is of a different length may affect the overall performance of the sensor.

Do not remove the shaft with torque applied to the sensor.

Interface description

Mechanical connection:

On the basis of the attached flanges, the sensor can be flanged for mechanical power transmission.

Electrical connector:

On the sensor housing there is an 8-pin socket for the power supply and the signal output (see chapter connection plan).

Operation (in regular case or in optimal case)

Optimal measurement parameters can be achieved if the sensor is applied in accordance to the specification. By compliance with the specification the sensor works generally trouble-free and maintenance-free.

Irregular operation, measures against disturbance

The mechanical overload on the sensor (e. g. exceeding of maximum allowed torque) may cause damage to the sensor and in consequence the incorrect signal output. In such cases please do not open the sensor. Contact **NCTE** directly for assistance.

Commissioning

After sensor installation pay attention to the following:

- The sensor may only be operated with a shielding.
- Switch on the power supply unit and check the supply voltage. Peak voltage must be avoided! Be sure to verify the power supply voltage before connecting the sensor!
- Connect the sensor to the power supply unit by using the delivered cable.
- Connect the sensor output to a high-resistance device such as an A/D converter, oscilloscope, PC measurement board. The sensor should be in mechanical unloaded state while connecting it.

Handling and transportation

By handling, storage and transportation keep the sensor away from magnetic or electromagnetic fields.

Precautions

- Do not open the sensor housing under any circumstances.
- Do not remove or loosen the locking rings on the shaft ends.
- Do not loosen or tighten the flange-mounting nut of the socket-connector (chapter dimensions).
- Use only a separate power supply for the sensor.
- Use the sensor only according to the specification (chapter technical characteristics).
- To protect your system, we recommend starting up the torque over several stages.

Maintenance and overhaul

As part of your testing and measuring equipment management, we recommend regular checking of your testing and measuring equipment. Please also observe the corresponding standards and guidelines.

Recommended NCTE maintenance plan

Recalibration	12 month
Control of wiring, plug and shaft	12 month

Repairs

Repairs must be carried out exclusively by employees of NCTE AG. The sensor must be sent to the NCTE AG together with an RMA formula (Return Merchandise Authorization). You will receive an RMA formula via the NCTE service-hotline.

Distributore italiano:



Telefono: +39 035 462678
email: info@luchsinger.it
www.luchsinger.it